



ikio
LED LIGHTING

Delivering Excellence. Brightening Lives.

LIGHTING ESSENTIALS

LEARN ALL ABOUT
LIGHTING

TRAINING MANUAL

PUBLISHED
10 | 04 | 2020



contents

Company Introduction **5**

Our History **6-7**

Technology & Manufacturing **8**

9 INDUSTRIES SERVED



10 COMMERCIAL LIGHTING

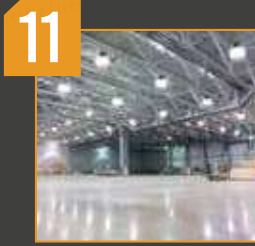

11 INDUSTRIAL LIGHTING



12 MULTI-FAMILY RESIDENTIAL & HOSPITALITY LIGHTING



13 HORTICULTURE LIGHTING



14 HAZARDOUS LOCATION LIGHTING



15 SOLAR OUTDOOR LIGHTING

1	Vision & Lights	16-22
2	Light & Color	23-29
3	Light Sources Characteristics	30-36
4	Incandescents	36-38
5	Fluorescent Lamps	39-43
6	HID LAMPS	44-47
7	LED LAMPS	48-51
8	Comparative Analysis	52-53
9	Industrial LED Lights	54-60
10	HazLoc LED Lights	61-64
11	Commercial LED Lights	65-71
12	Horticulture LED Lights	72-74

13	Multifamily Residential & Hospitality LED Lights	75-80
14	Solar LED Lighting	81-84
15	Low Voltage Lamps	85-88
16	LED Power Supply	89-91
17	Certifications	92-96
18	Industry Standard Tests	97-100
19	Luminaire System Performance	101-103
20	Lighting Controls	104-108
21	The Quantity & Quality of Light	109-113
22	Lighting Design	114-118
23	Lighting & Space	119-122

COMPANY INTRODUCTION

WHO WE ARE

KIO LED Lighting is a leading US-based manufacturer of Commercial, Industrial and Multi-family Residential / Hospitality, Hazardous Location and Solar Outdoor LED Lighting.

COMMERCIAL LIGHTING

MULTI-FAMILY HOUSING & HOSPITALITY LIGHTING

INDUSTRIAL LIGHTING

HORTICULTURE LIGHTING

HAZARDOUS LOCATION LIGHTING

ikio
LED LIGHTING

Your One-Stop Destination for all **Lighting Needs.**

- Wide range of over 1100 DLC listed and I350 UL certified products.
- Warehouses across the USA, with a Ready-To-Ship inventory.
- Products refined for High Performance & Value.
- Factory Direct Advantage.

With a wide range of sustainable products, we deliver the right solutions and value for LED Lighting requirements to our customers. And we do this by employing an innovative approach to our operations. Our manufacturing setup incorporates vertical integration and is capable of churning out new generation LED lighting products consistently without compromising quality. Our six ISO & OHSAS certified state-of-the-art manufacturing plants have a combined manufacturing capacity of 10 million fixtures annually. With an in-process rejection rate of less than 0.68%, we strive to demonstrate our firm belief in 'quality over everything' philosophy time after time.



OUR HISTORY

The IKIO Group began its manufacturing journey in 1987 with rotary switches and potentiometers under the brand of Fine Technologies. In just 30 years, the Group grew from being a small electronics and component manufacturing operation to a global manufacturing operation.

The immense manufacturing know-how enabled us to foray into the manufacturing and marketing of LED lighting systems in 2005. With our robust expansion, we are not just breaking our year over year records in the Asian and Middle-eastern markets, but also

IKIO LED Lighting Our Story So Far

2005-2010

THE FOUNDATIONS WERE SET



This is when our mentors put in the hard work and set up the IKIO Global group. The firm foundation for IKIO LED Lighting was established.

OUR IKIO STORY BEGINS

2012

We had humble beginnings and started a small-scale business operations out of a garage in Indianapolis. It all started with limited SKUs and insignificant sales volume.



2015

HELLO NEW OFFICE!



Sales were beginning to grow and IKIO was getting bigger. This is when we moved to our brand new corporate office and setup a warehouse carrying an inventory worth \$ 3 million.

2017

JOINING THE LEADING PACK



From a small start-up, we gradually equipped ourselves to join the industry leaders. With a comprehensive product portfolio (1200+ products) and a much bigger team, we were officially in the super-growth mode.



increasing our presence rapidly in the US. With multiple projects successfully delivered across the country, we have positioned ourselves as a leading US brand, best in its class for providing customized solutions in LED Lighting.

Today, here at IKIO, we are spearheading the revolution of LED lighting innovation through our consistent focus on R&D and operational optimization. This endeavor has resulted in the development of sustainable products that are changing the landscape of the lighting industry and energy conservation.

OUR LFI DEBUT 2018

This was when we decided to shout out loud and announce our big arrival. Participating in LFI became one of the major game changers in our history.



lightfair

FULL STEAM AHEAD! 2020

The new year was initiated by a bold growth outlook of 150% and a host of networking and expansion operations for IKIO LED Lighting, Inc. 5000 series rated us the second fastest growing manufacturing company in the Midwest. We have firm plans to launch our Solar Outdoor Lighting Range and partake in innovation awards with our patent-pending products.



2019 ASSOCIATIONS & MARKET EXPANSION



IKIO becomes an official NAESCO Energy Affiliate and its Gold Sponsor. We were now also selling thorough multiple channel partners and expanding our product range ever further.



TECHNOLOGY & MANUFACTURING

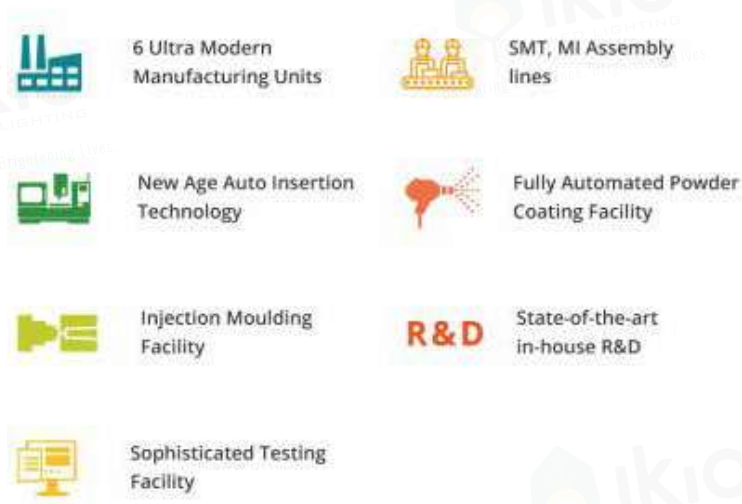
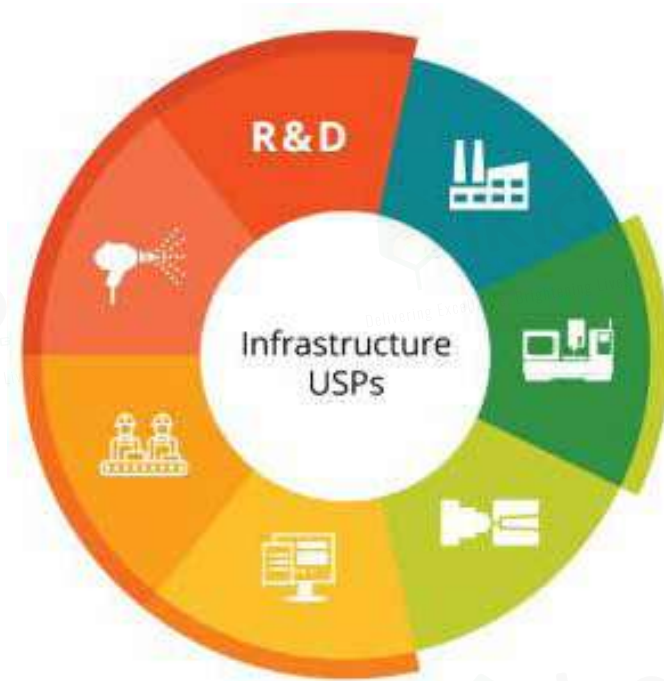

Some key facts:

- Annual manufacturing capacity of over 10 million fixtures.
- 6 Manufacturing plants with a combined area of over 2.5 million sqft.
- Development of comprehensive energy-saving solutions using lean systems.
- Continuous and consistent focus on R&D with the help of a world-class team of engineers.
- Vertically integrated manufacturing setup with in-house automated powder-coating and injection molding facilities.
- In-process rejection rate <0.68%.
- Major quality certifications like ISO 9001, 14000 & 18001, and OHSAS.
- Stringent and no-compromise quality testing and analysis using spectrometers, goniophotometers, thermal chambers, LCR meter, isolation tester, etc.



INDUSTRIES SERVED

With more than 1300 Rebate Eligible products in our portfolio serving a plethora of applications, we are one of the largest manufacturing companies leading the innovation in LED lighting technology.



COMMERCIAL LIGHTING

What makes lighting one of the most important aspects of any commercial establishment is the fact that it can have a direct impact on the most crucial dimensions of buying decisions like value, aesthetics, performance and user experience. This segment requires a deep understanding of the growing needs of not just cost optimization and value engineering in commercial applications, but also the importance of performance improvement and an expansion of the scope of applications.

■ WIDELY USED FIXTURES:

1. Tubelights
2. Troffers
3. Panel lights
4. Magnetic Strips
5. Refrigeration Lights
6. Tri-proof Luminaires

■ APPLICATIONS:

Interiors of retail spaces, offices, transport hubs, hospitals, and educational facilities.

INDUSTRIAL LIGHTING

Having an optimum lighting solution for industrial spaces is prudent in the 21st century to ensure the safety of workers, enhance work productivity while ensuring efficiency in costs. Operational optimization and cost scrutiny across every process are the major driving forces in this segment. The ideal lighting choices in this application are required to offer a high level of reliability, durability and low maintenance. The unique characteristics of LED Lighting are thus a major driving factor for the growth of LED applications in this segment.

WIDELY USED FIXTURES:

1. UFO Highbays
2. Low bays
3. Linear Highbays
4. Floodlights
5. Canopy Lights
6. High Mast Lights
7. Area Luminaires
8. Wall Packs

APPLICATIONS:

Interiors and outdoors of Industrial facilities like warehouses, processing plants, airport hangers, production units, parking lots, shipping yards, etc.



MULTI-FAMILY RESIDENTIAL & HOSPITALITY LIGHTING

Years of research has shown that indoor light and its quality has a significant influence on our mood and our ability to feel relaxed. At homes and hospitality spaces, lighting efforts aren't just driven by cost-effectiveness, but more importantly by the preservation of colors and liveliness. Factors like style, finish, CRI, CCT, and smart controls are the most sought after qualities that drive the growth of LEDs in this segment. Furthermore, the unique factors of LED, such as energy efficiency and high durability are also sought by American homeowners and hospitality managers as they bring down lighting costs significantly.

WIDELY USED FIXTURES:

1. Recessed Downlights
2. Flush Mount Fixtures
3. Sconces
4. Bath & Vanity Fixtures
5. Undercabinet Lights
6. Porch Lights
7. Outdoor Lights

APPLICATIONS:

Interiors and outdoors of multifamily residences, apartments, motels, restaurants, lodging, recreation spaces, etc.

HORTICULTURE LIGHTING

The explosive growth in the horticulture industry has upped the requirement of horticulture lights exponentially. LEDs add remarkable advantages in this application with their energy and water savings while actively achieving higher plant growth rates. The two segments of Horticulture Light Fixtures that exist in the markets today are Toplighting and Interlighting.

LED Toplighting shows promising results of shortening growth-cycles, increasing yields, reducing energy and enabling more economic use of space.

LED Interlighting directs and focuses growth-stimulating light on the most vital the crop. Its sideward light distribution allows leaves to transform the light to growing more yield parts of



Figure 2. Horticulture Lighting Segments

FIXTURE SEGMENTS:

1. Toplighting and Interlighting fixtures.

APPLICATIONS:

Floriculture, greenhouse cultivation, water soluble breeding, pipeline cultivation, etc.

HAZARDOUS LOCATION LIGHTING

Explosion-proof lights are deployed in Hazardous Location (HazLoc) Lighting applications to ensure the safety of not just the workers, but also businesses. In 2018-19, the LED HazLoc lighting segment grew by 11% compared to the previous period. Increasing government regulations promoting LED lighting for worker safety in remote and hazardous areas is a major growth driver for this segment. With the advent of LEDs, Explosion-proof LED lights have become a strong competitor to traditional fluorescent and HID counterparts, with its high efficiency and low operating costs. They use more than 90% of the energy to produce light and have near-zero heat or conversion loss to account for, which means that they use a lot less power to function. Organizations save on-site energy from portable generators and other in-situ sources, providing more sustainable and profitable operations.



1. UFO Highbays
2. Lowbays
3. Linear Highbays
4. Floodlights
5. Jelly Jar Lights
6. Trouble Work Lights
7. Signages, etc.

APPLICATIONS:

Oil refineries, gas stations, pumping stations, warehouses, manufacturing plants, power plants, etc.

Substance	Substance Class	Area Classification		Hazardous Location Characteristics
		NEC500	NEC505	
Gases / Vapors	Class I (NEC 501)	Division 1	Zone 0	Explosion hazard present continuously or occasionally under normal operating conditions
			Zone 1	
		Division 2	Zone 2	Ignitable concentrations of flammable gases or vapors are not normally present, but could be present in the case of a fault
Dusts	Class II (NEC 502)	Division 1		Combustible dusts are presents in quantities sufficient to produce explosive and ignitable mixtures
		Division 2		Combustible dust due to abnormal operations may be present in quantities sufficient to produce explosive or ignitable mixtures
Fibers	Class III (NEC 503)	Division 1		Easily ignitable fibers / flyings are handled or manufactured
		Division 2		Easily ignitable fibers / flyings are stored or handled

SOLAR OUTDOOR LIGHTING

The outstanding efficiency of LED lights makes them perfect for solar lighting applications. These lights are virtually free of operational energy costs as they derive their electricity from cells powered by the sun. Another interesting aspect of these lights is the sensors and remote controls that come on board, making them easier to operate.

POPULAR INTEGRATED SOLAR FIXTURES:

1. Streetlights
2. Plaza Lights
4. Landscaping Decor Lights
5. Outdoor Lights, etc.

APPLICATIONS:

Outdoor areas that receive abundant sunlight.



Vision & LIGHT



1 > Light and The Eye

The process of vision (in humans) is mainly facilitated by:

- Light Source
- An Object
- Eyes-the Receptor
- Brain-the Decoder

Light Source

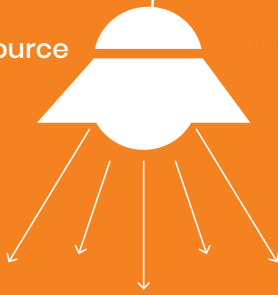

Object



Receptor & Decoder



Figure 5. The process of vision in humans.

The Light Source emits light rays that are reflected from the Object which are captured by the electro chemical receptors in our Eyes. The Eyes then transmit signals to the Brain which decodes these signals and enables vision. The brain and the eye work in tandem to transform radiant energy into the sensation of seeing.



2 » Light and The Eye

The Light that we see is electro-magnetic energy emitted in the visible portion of the spectrum. While light results from combining different wavelengths of visible energy, the eye responds to electro-magnetic energy-wavelengths in the range between ultra-violet and infra-red radiation. The eye is most responsive to the yellow-green portion of the spectrum.

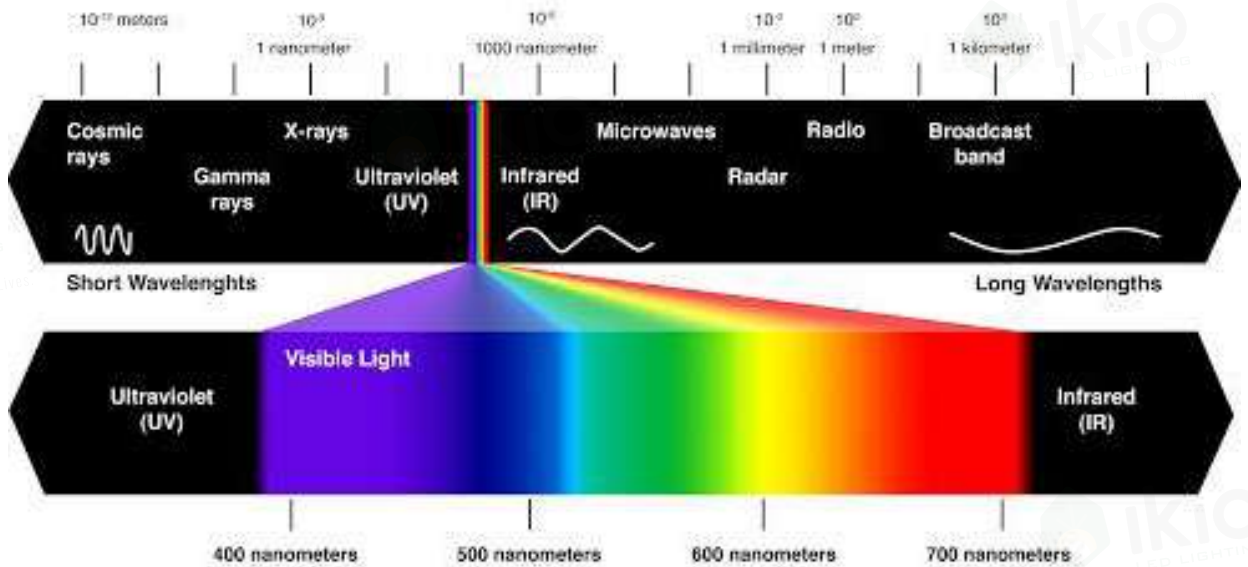
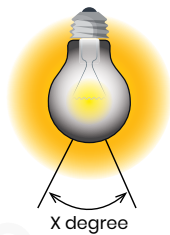

Figure 6. Wavelength chart explaining Visibility Spectrum

3 » Measuring Light & Delivered Light

Luminous Flux (cd)
(Total light emitted by a light source in all direction)



Luminous Intensity (Im)
(Light emitted towards a specific direction within a given angle)

Luminance (cd/M²)
(Light reflected to eyes)



Illuminance (Ix)
(amount of light falling on 1 m² area)

Figure 7. The units of light measurement

Instead of lumen output, the best and most relevant measurement for evaluating LED lighting fixtures and for making accurate comparisons with conventional lighting fixtures is delivered light.

The formal term for the measurement of delivered light is illuminance which is the intensity of light falling on a surface area. If the area is measured in square feet, the unit of illuminance is footcandle. If measured in meters then the unit is lux.

Because LED lighting fixtures are fundamentally

directional and create white and colored light without filtering or additional lensing and shading, LED fixtures typically waste much less light than their conventional counterparts, and deliver more of their total light output to a task or target area.

An LED fixture with lower-rated lumens, therefore, may deliver the same or more useful light in a specific application than a comparable conventional lighting fixture with a higher rated lumen output.

4 » Brightness

Lighting Professionals distinguish between "Luminance", which we measure, and "Brightness", which we perceive. Brightness is subjective and depends on the visual environment.

To see, there must be light, an object, a receptor (the eye) and a decoder (the brain). We do not

see illuminance or footcandles; rather, we see brightness resulting from light transmitted or reflected by a surface. This brightness is called Luminance and is measured in Candelas per square meter (cd/Sqm). There is always a subtractive interaction between a surface and the light falling on it; some light is always lost due to absorption.

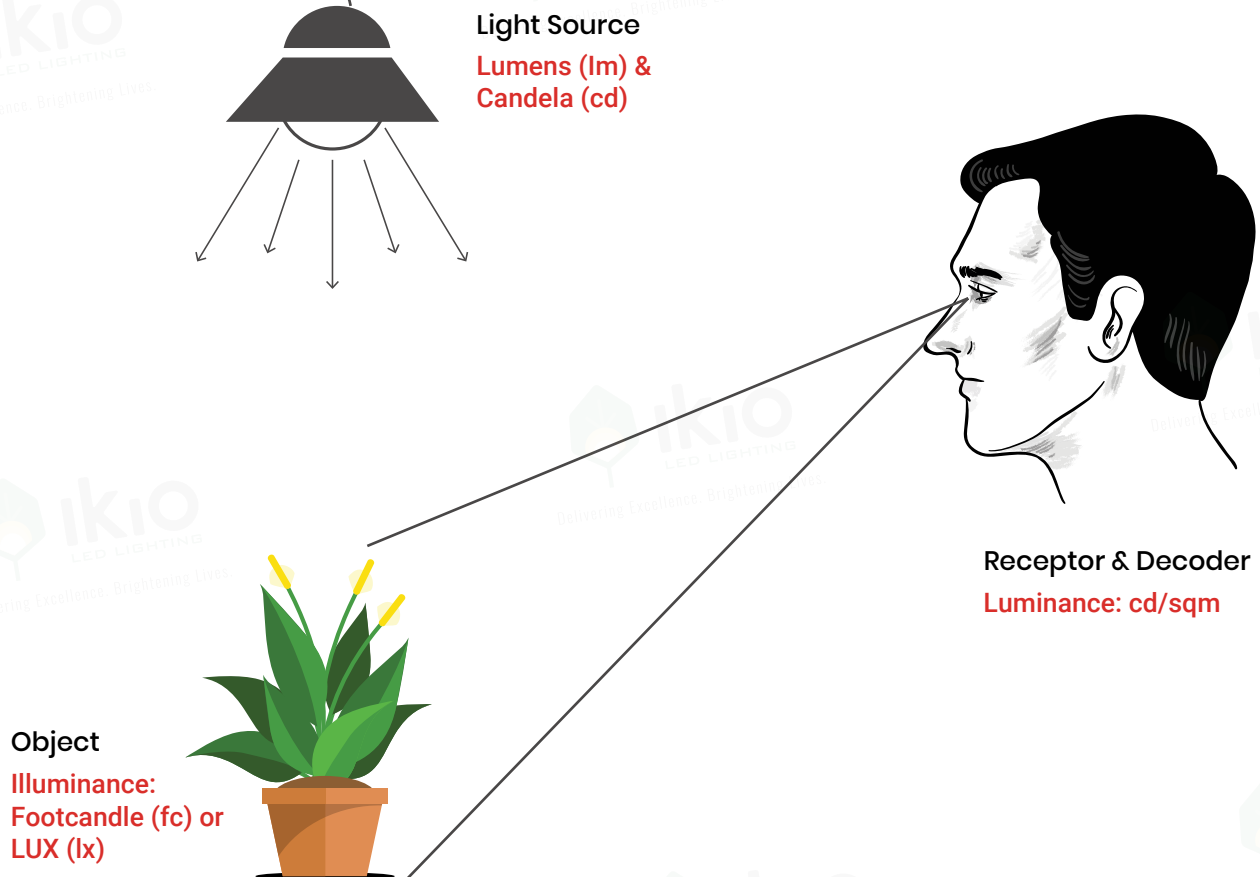



5 » Visual Field

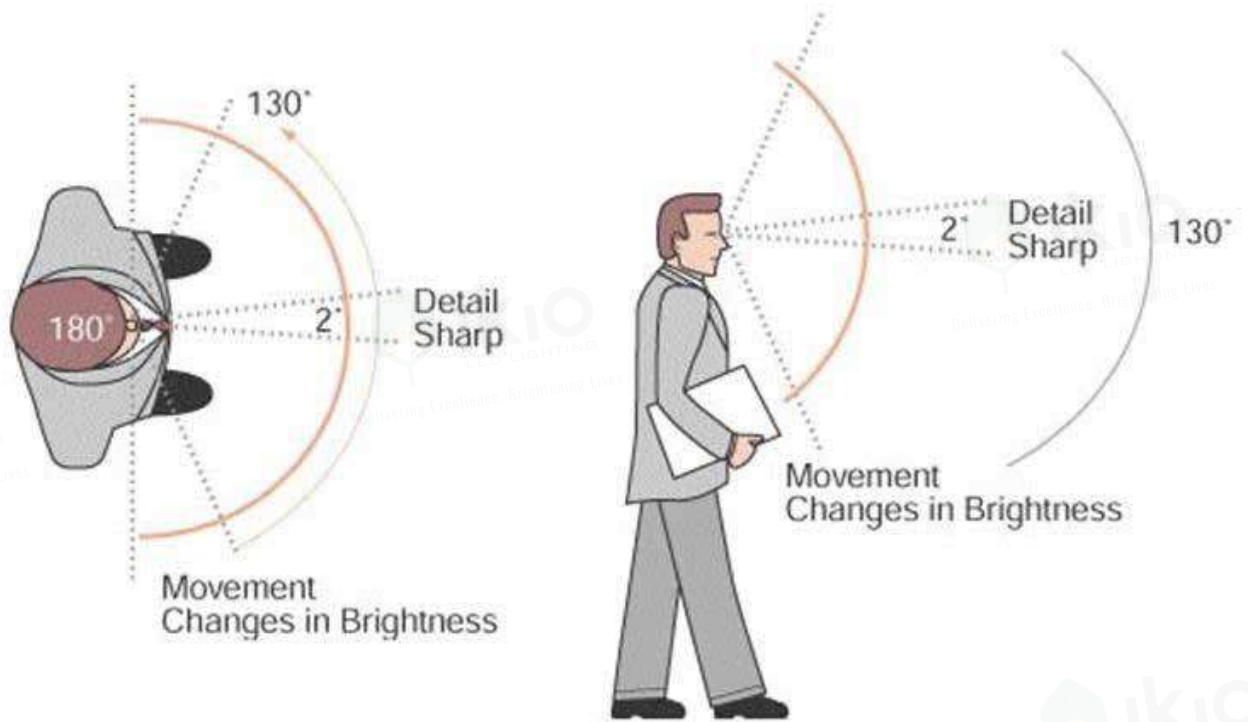
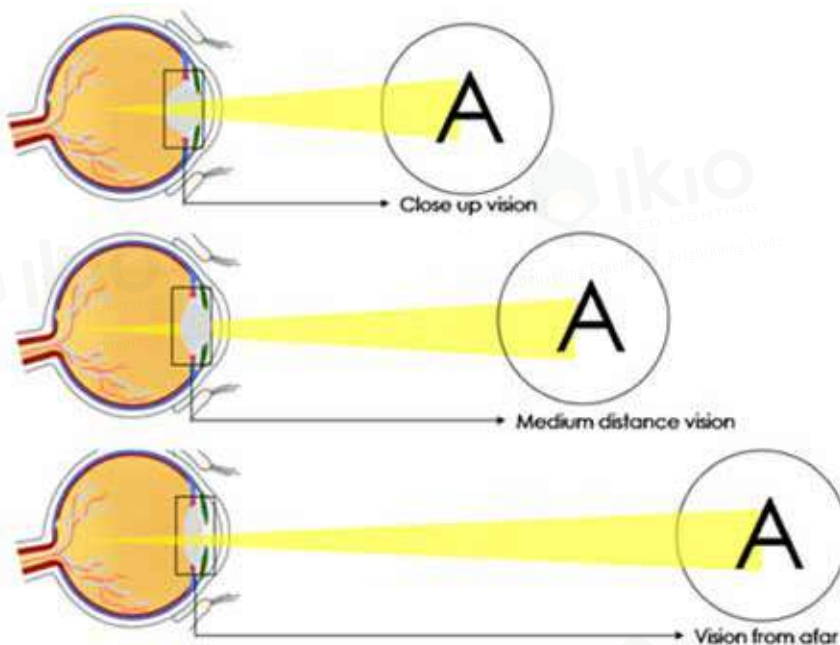

Figure 9. The horizontal and vertical visual fields

The Visual Field is the area the eye sees. It normally extends 180 degrees in the horizontal plane and 130 degrees in the vertical.

6 » Visual Accommodation



Visual Accommodation is the process by which the eye locates and focuses on an object.

The nearer the object, the more convex the lens of the eye will be.

The farther the object, the flatter the lens. Prescription glasses compensate for the inability of the lens to change shape sufficiently to provide clear vision.

Figure 6. Wavelength chart explaining Visibility Spectrum

7 » Visual Adaptation

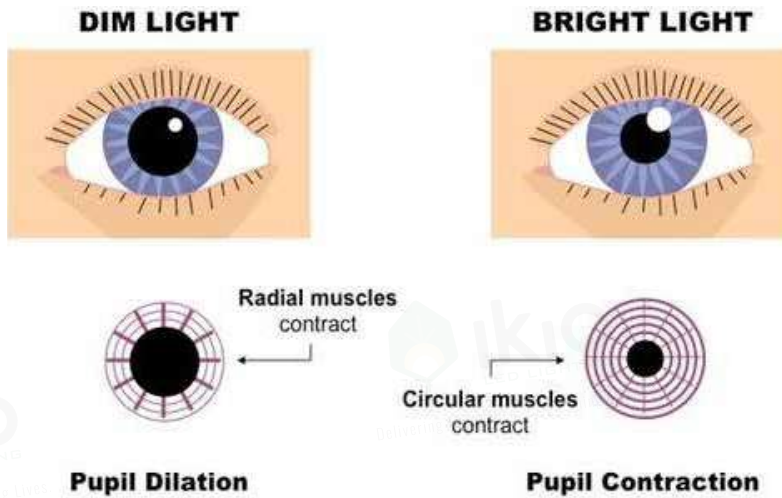

Figure 11. Visual Adaptation

Adaptation involves the size of the pupil opening and sensitivity of the retina.

The pupil of the eye opens wide in low levels of light and gets smaller as the light level increases.

A change also occurs in the photochemical substances of the retina. It takes longer to adapt from light to dark - like going into a movie theatre in the daytime - than it does to adapt from dark to light.

8 » Visual Range

	Area	Foot Candles
	Living Room	10 - 20
	Kitchen Stove	70 - 80
	Kitchen Sink	70 - 80
	Kitchen General	30 - 40
	Dining Room	30 - 40
	Bathroom	70 - 80
	Bedroom	10 - 20
	Hallway	5 - 10

The range of visual experience extends from moonlight (.01 footcandle) to summer sunlight (10,000 footcandles).

Most commercial interiors are illuminated from 5 to 100 footcandles, depending, primarily, on the activities within the space.

Figure 12. Foot-candle figures on the left are for typical conditions and the calculations are for 8ft ceilings.

9 » Visual Field

Twenty/twenty vision is what normal 20-year-olds can see at twenty feet. The eyes of a healthy twenty-year-old adjust quickly and easily to changes in brightness in the environment.

Older eyes have more difficulty accommodating and adapting; they need more light and should be protected from glare. As the eyes age, they lose their elasticity, reducing their ability to accommodate easily. Adaptation from one light

level to another takes longer and the range of sensitivity drastically diminishes the ability to see at low light levels.

A sixty-year-old needs ten times as much light as a normal twenty-year-old to perform the same seeing task with equal speed and accuracy. Additionally, older eyes are disabled by glare to a much greater extent. adapt from dark to light.



10 » Visibility Factors

The four factors that together, determine visibility are:



Figure 13. Size & Contrast acuity test

Size- The bigger or nearer the object, the easier it is to see.

Contrast- The difference between the luminance of an object and that of its background is called contrast. Black letters on white paper are easy to read because the contrast approaches 100%. But grey lettering with only 40% reflectance on grey paper of 80% will have a contrast of only 50% and be hard to see. The visibility of a low contrast object can be increased by adding illumination or the use of colors.

Luminance- Luminance is the amount of light reflected or transmitted by an object. A dark-colored surface reflects less light than a light one, hence more illumination is required on a dark surface to equal the luminance of a similar light

surface. The luminance of a task, like reading, is a key factor of visibility. Increasing the luminance of an object by bringing it close to a source of light, increases its visibility.

Time- The lower the visibility, the longer it takes to see details. Small size, poor contrast, and low illumination all increase the time needed. The time factor is especially important where motion is involved, as in driving. Under low light levels, an object appears to move more slowly than under high levels of illumination.

It is important to note that these factors are inter-related and improvements in one can set off problems in another.



2 » Light & COLOR



1 » Introduction

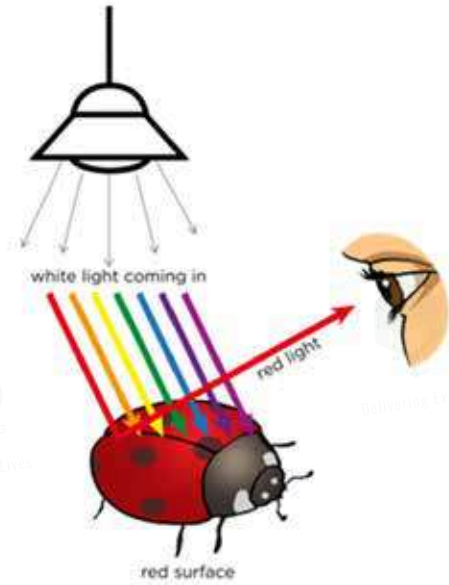

Figure 11. Visual Adaptation

We can all agree that color is a major factor in the aesthetics of any space. Without light, however, we can't perceive color. There are two aspects to color recognition:

Light Source Color: which involves the spectral composition of the light falling on an object

Object Color: which involves the reflectance characteristics of an object

We see "color" because an object selectively reflects a certain portion of the light falling on it. For instance, in the figure on the left, we perceive the ladybird (object) as red because it selectively reflects red (color) from the spectrum of light that falls on it.

2 » Object Color

The color of objects from pigment, dye, or paint function as selective reflectors. They reflect the light of that color. As we learned, white light consists of energy radiated throughout the visible spectrum.

Complementary colors (red/green, blue/orange) can be seen under it. If however, a green leaf on

a red apple was lighted with only red wavelengths of light, the leaf would appear without color or "black". If the apple were lighted with only green light, it would appear "black" but the leaf would be perceived as green. If a color is not in the light source, it cannot be seen in the object.

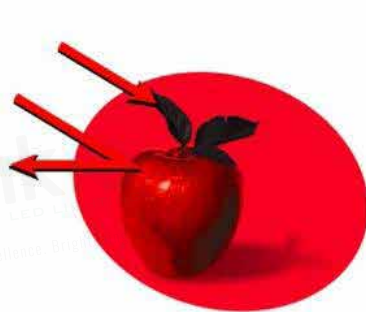

In red light, the apple appears red because it reflects the red light. But the leaves look black.



In green light, the apple appears black because no red light strikes it. But the leaves look green.



In blue light, both the apple and the leaves appear black.

Figure 15. An object under different wavelengths of light

3 » Spectral Power Distribution (SPD)

The color composition of any light source can be drawn by plotting the amount of radiant power at each wavelength.

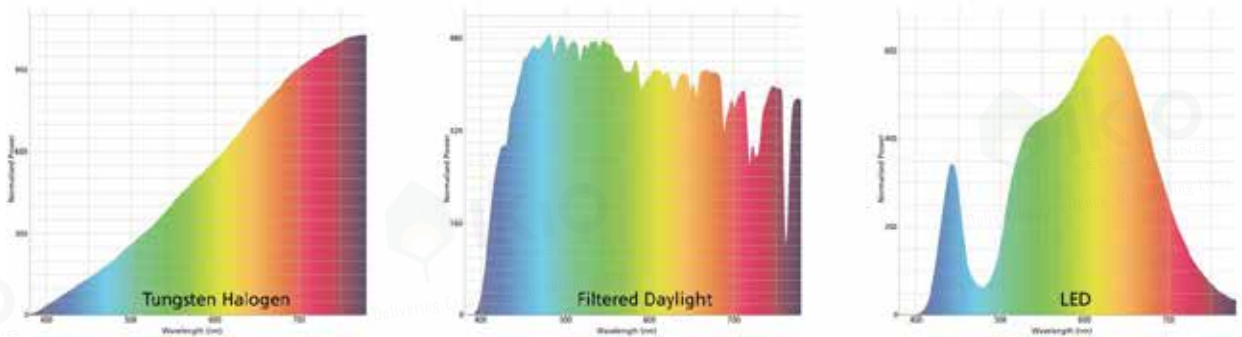

Figure 16. Spectral curves for three light sources

This is known as a Spectral Power Distribution Curve. Each light source can be precisely described by its SPD curve. The higher the curve at any point, the more power there is in the light

source at that wavelength. The curve shown for Filtered Daylight is relatively balanced, with power at all wavelengths, whereas, the Tungsten halogen curve rises highly for the color red.

4 » SPD & Color Rendering



Figure 17. Area in blue-rich and red-rich lighting

The SPD curve indicates the color rendering properties of a light source. A source with a lot of radiant power in red and orange light will enhance those colors. A source rich in blues and greens will emphasize those. Similarly, a source that is weak at one end of the color spectrum will tend to gray or dull those colors.

As we saw in Fig.15, a source with just one color, such as pure red, reveals just that color and no others.



5 » Warm & Cool Lights

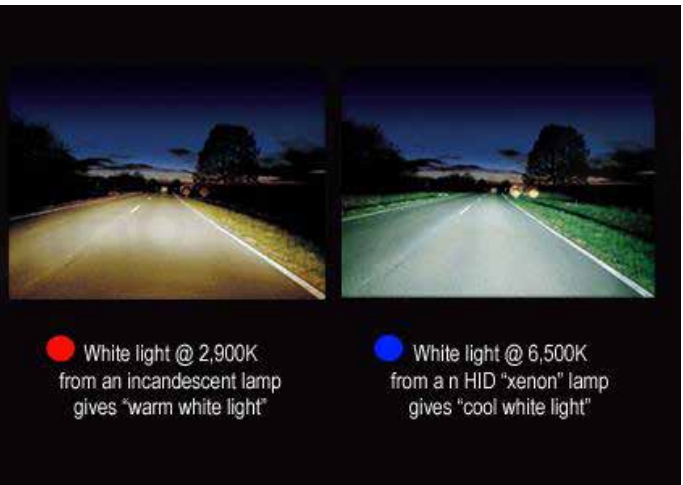
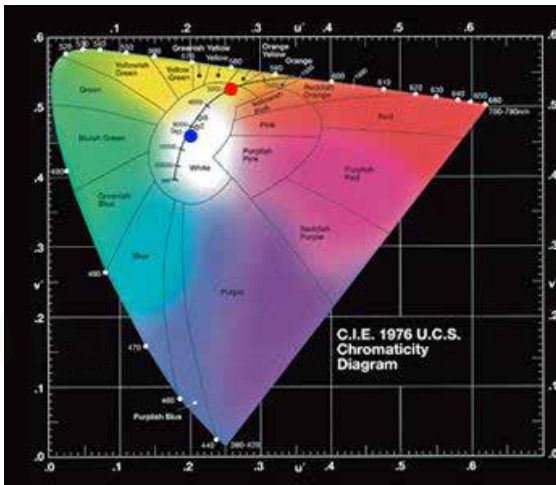

Figure 18. Vanity area in warm white and cool white lights

We use the terms Warm and Cool to characterize the various colors of white light. These are subjective terms that perhaps correspond to experiences formed well before the invention of electric lighting.

Warm refers to light sources that are rich in reds and oranges, perhaps evoking firelight or candlelight. Cool refers to light sources rich in blue; think of a North sky. Note that warm and cool do not refer to the temperature of the light.

6 » Chromaticity



White light @ 2,900K from an incandescent lamp gives "warm white light"

White light @ 6,500K from a HID "xenon" lamp gives "cool white light"

Figure 19. Chromaticity Diagram mapping warm white light and cool white light sources

The CIE Chromaticity Diagram, above, permits light sources to be described by their coordinates on the graph. The graph also

permits all sources to be plotted together on a single graph. The Chromaticity Diagram helps, but for everyday use, we need still simpler tools.

7 » Color Temperature

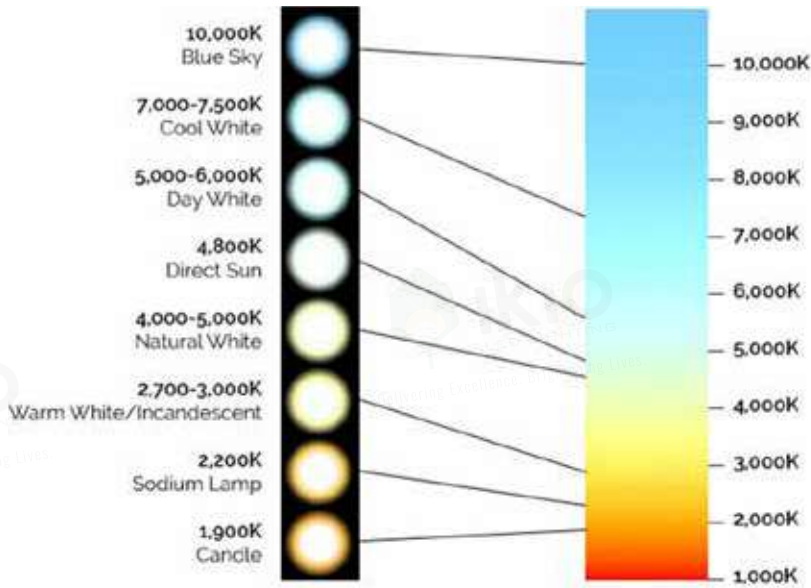

Figure 16. Spectral curves for three light sources

Many of our customers are now familiar with the idea of a warm white or a cool white being offered by fluorescent and other light sources.

The scale used for Color Temperature is degrees Kelvin (K).

Warm color temperature is typically 3,000K or less. A cool white bulb commonly has a color temperature of 4,000K and higher on the Kelvin scale.

8 » Correlated Color Temperature

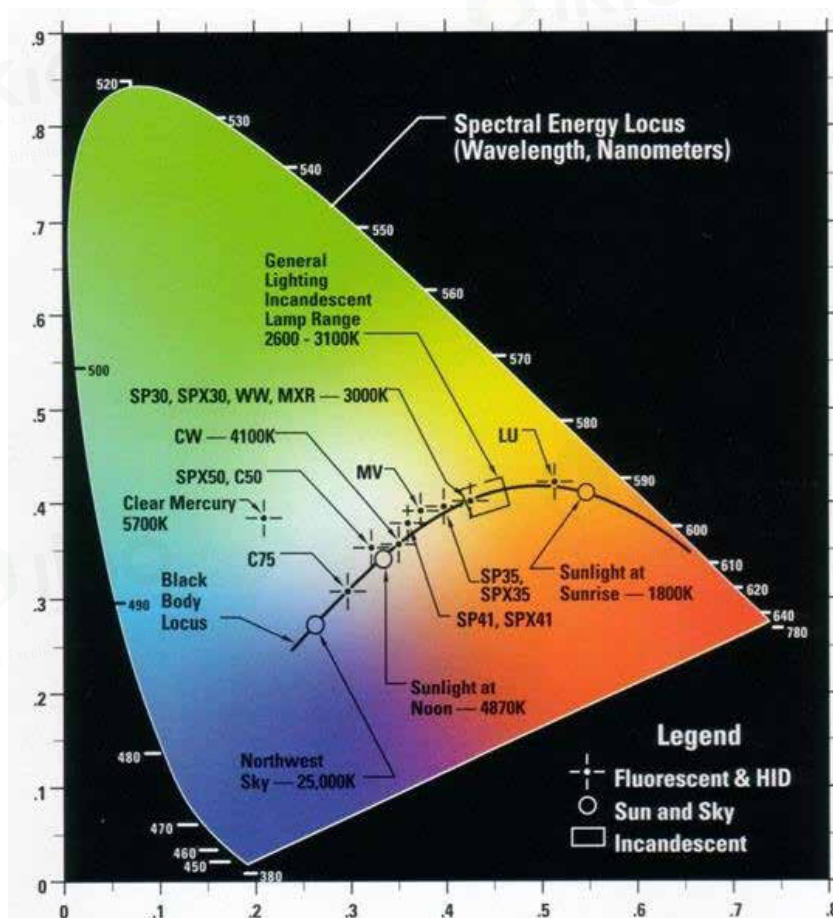

In calculating the color temperature of light sources, we use a theoretical model called a Black Body Radiator.

Note that the Black Body is a continuous spectrum source, with radiant power at all wavelengths.

The chromaticity of the Black Body Radiator at various color temperatures is plotted on the diagram below. Incandescent sources fall on the Black Body line, between approximately 2600K and 3100K. LED sources fall on the Black Body line between approximately 2200-K and 6000-K.

Figure 21. Black Body Locus on CIE chromaticity diagram



9 » Color Rendering Index

A color rendering index (CRI) is a quantitative measure of the ability of a light source to reveal the colors of various objects faithfully

in comparison with an ideal or natural light source. It is measured on a scale from 1 to 100, with 100 representing daylight.



Figure 22. Objects under different CRIs

The higher the CRI of a light source, the more “natural” colors will appear under it. Light sources with a low CRI will distort colors. Note that we say “natural”, meaning as seen in daylight or sunlight. Since an object looks different according to the color in the light illuminating it we do not say “true”

color Incandescent sources, which are also heated metal, also have a CRI of 100. Fluorescent and LED sources have CRIs of less than 100 (although some are quite high as we shall see later).

10 » CRI & CCT

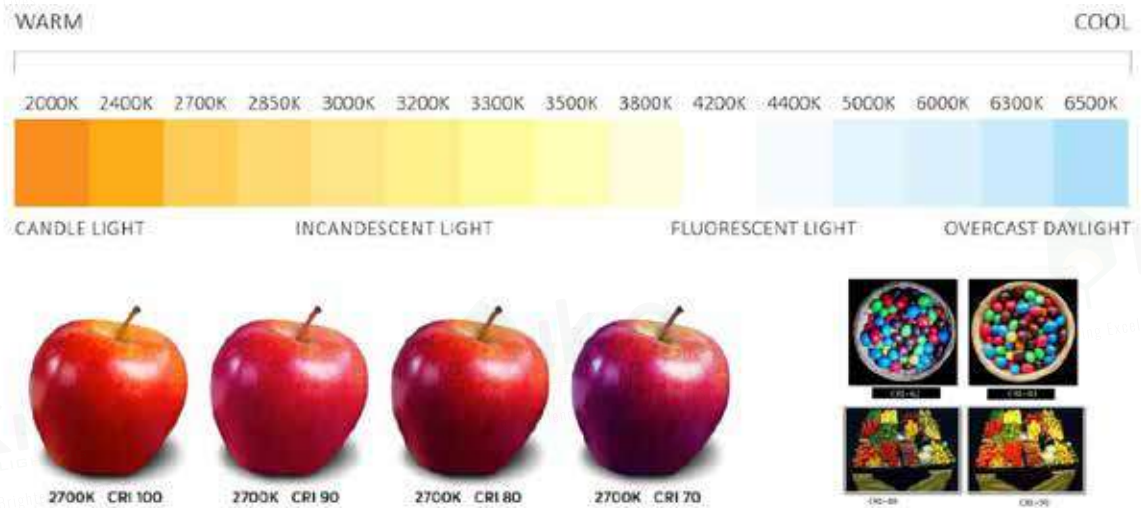

Figure 23. Using CRI & CCT for color rendering

Consider two light sources with different spectral compositions. They can have the same Color Temperature and both be called “warm”, but they will render colors differently. And sources with the same CRI but

different CCTs will also render color differently. Since the CRI of a light source depends on its Color Temperature, these two measures of light source color need to be used together.



1 1 » Conclusion

- We only see object color when that color is present in the light source.
- Spectral Power Distribution describes the color composition of a light source and is expressed in kelvin.
- Color Temperature describes the apparent color of a white light source using the Kelvin scale.
- Warm and Cool are subjective terms to describe the color of light.
- Color Rendering Index describes how well a light source renders colors naturally.



3 »

Light Sources **CHARACTERISTICS**

1 » Introduction

Every member in the family of light sources has different characteristics in terms of:

- Output and Efficacy
- Lamp Life
- Color
- Optical Control and Texture Rendition
- Operation (variation in output, ballasts and transformers, dimming, and attachment)



Figure 24. (From the left) A-Series Lamps: HID, Incandescent, CFL and LED

High-Intensity Discharge (HID) lamps create light by exciting gas atoms with an electric arc, emitting (discharging) visible radiation. The term HID includes Metal Halide, Mercury and High-Pressure Sodium lamps, each of which features a different gas mixture.

Incandescent lamps illuminate when an electric current runs through a wire filament and heats the filament until it starts to glow

CFLs produce light when an electric current is driven through a tube containing argon and a small amount of mercury vapor. This generates invisible

ultraviolet light that excites a fluorescent coating (called phosphor) on the inside of the tube, which then emits visible light.

A **light-emitting diode (LED)** is a two-lead semiconductor light source. When a

suitable voltage is applied to the leads, electrons can recombine with electron holes within the device, releasing energy in the form of photons. LED's have many advantages over incandescent and HID light sources including lower energy consumption, longer lifetime, improved physical robustness, smaller size, and faster switching.

2 » Output & Efficacy

	Incandescent	Fluorescent	Mercury	Matel Halide	High Pressure Sodium	LED
Efficacy - LPW	15-22	50-100	50-63	70-90	65-95	80-110
Average Rated Life (hours)	750-12,000	7,500-24,000+	24,000+	5,000-20,000	16,000-24,000	50,000-125,000

Figure 25. Chart for efficacy and rated life for various light sources

Efficacy (also called luminous efficacy) relates a lamp's output to the power required for operation. Efficacy is measured in lm/W. The higher the efficacy, the more energy-efficient the light source, and the less it will cost to operate over its life. Incandescent lamps have much lower efficacy than either fluorescent or HID lamps. LED sources offer the highest output in a single lamp.

A lamp's output is measured in lumens. The lumen rating of a new lamp is called its Initial Output. Over time, the output diminishes; this is called Lumen Depreciation. Lumen depreciation is low for incandescent sources it varies for fluorescent and HID lamps.

L70 Standard: Average Rated Life

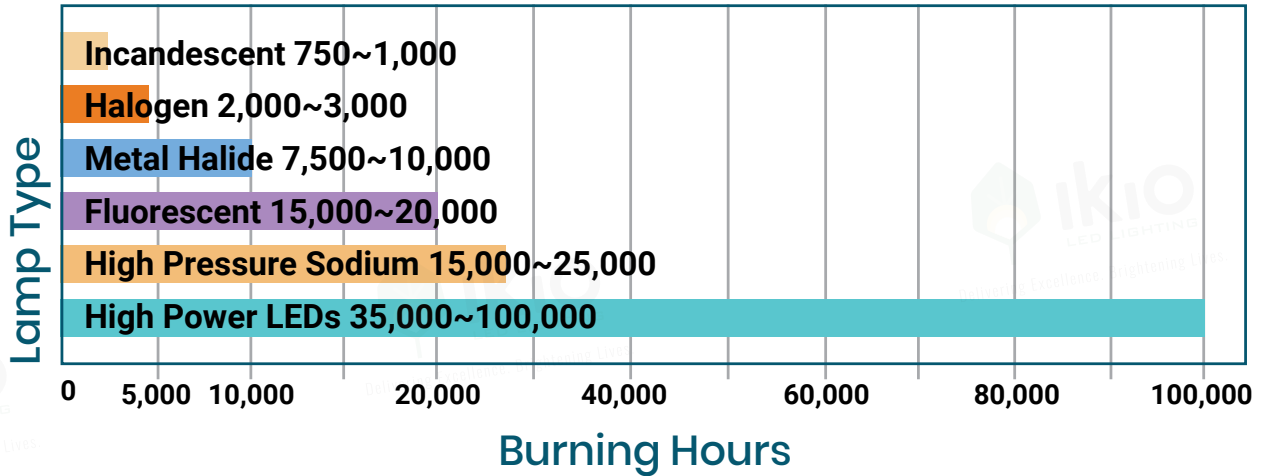
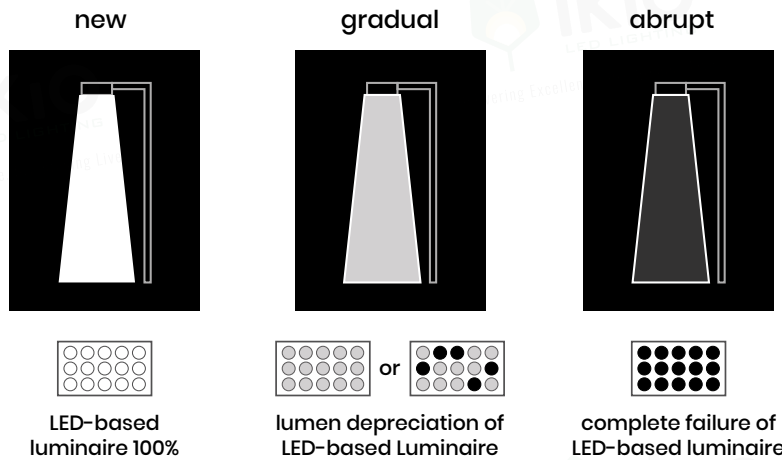

Figure 26. Typical lamp lifespan

Traditional source lifetime is calculated according to the B50 standard. In this standard, the lifetime of the source is the number of operating hours after which 50% of the tested lights fail. Technically, this average is termed a median.

Since LED is a semiconductor, it will not burn out like a Halogen or a CFL. Instead, the lighting output will decline over time. As a result, the L70 B50 standard was developed.



Based on lumen depreciation of the LED, the L70 B50 standard considers the lifetime of a source to be the number of operating hours at which half of the tested population reaches 70% of the initial lumen output (30% lumen depreciation). Below this point, it is considered that the source does not fulfill its lighting requirements and should be replaced.

Figure 27. Lumen depreciation stages of LED lamps

4 Color

All non-color light is emitted in a spectrum. It is a combination of many frequencies. Ideally, the output of different frequencies across the spectrum from red to blue is equal. If the output is not equal then there can be spikes or valleys in the output. Continuous or full-line spectra produce less color distortion of objects than a discrete line or band spectra.

As you can see above, Daylight has a continuous

spectrum. Given how they produce white light, even warm white LEDs have a discontinuous spectral quality in comparison. In the case of halogen lamps, the spectral lines are somewhat continuous. Incandescent lights have a mostly continuous spectrum as well, with very little blue in their band spectra. Fluorescent lamps usually have a great number of spikes and valleys in their band spectra which suggests their color output is subpar.

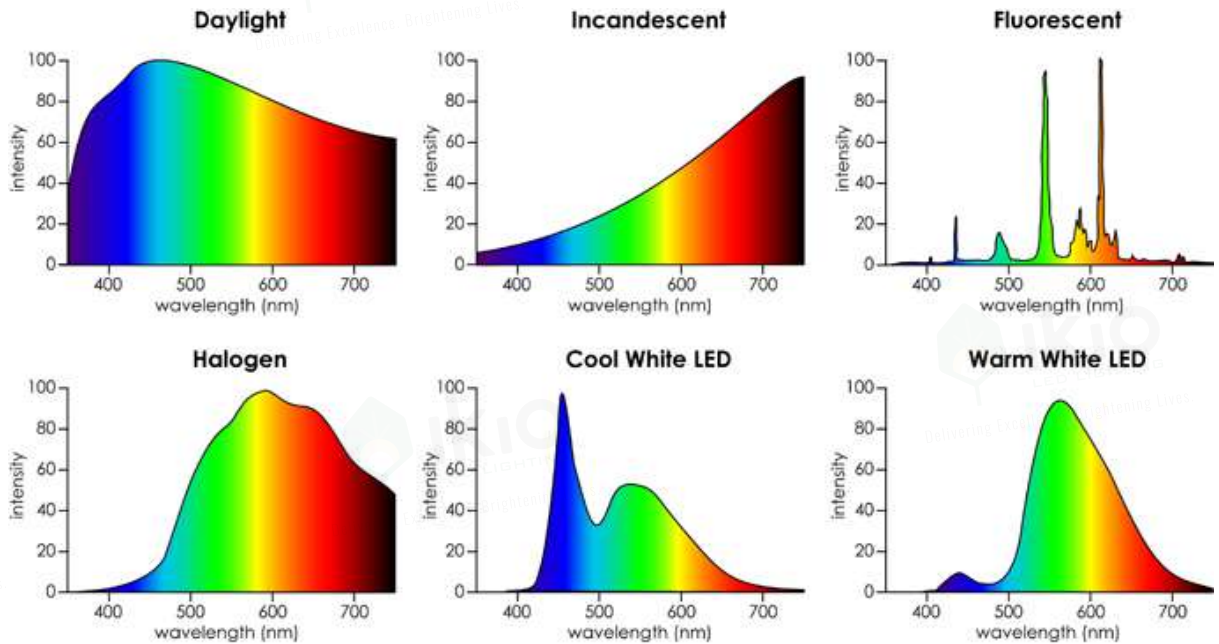

Figure 28. Spectral diagrams for different light sources

5 » Optical Properties

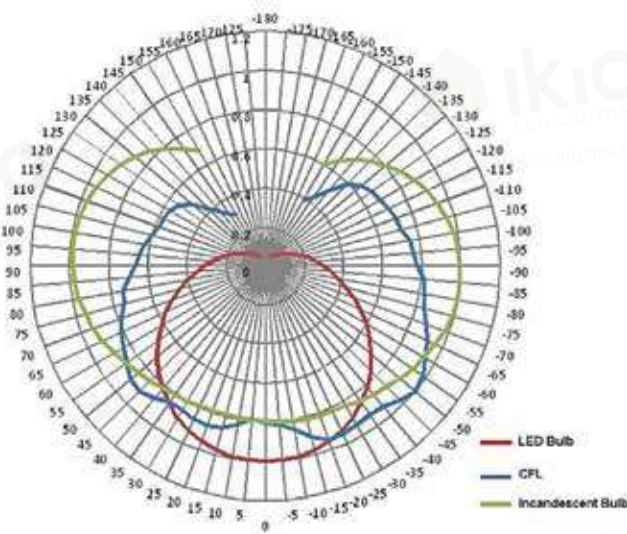

Figure 29. Comparison of intensity distributions of different light bulbs: LED bulb (Red Curve), CFL (Blue Curve), and incandescent light bulb (Green Curve)

Some HID lamps feature compact arc tubes and clear glass enclosures, which permit optical control approaching that of many incandescent lamps. Other HID lamps have large, phosphor-coated bulbs which are harder to control.

6 » Optical Characteristics

The smaller a directional source and the tighter the beam, the greater the contrast between light shadow will be. The larger the light source, the less directional it is and the greater the number of angles at which light strikes the object, which

softens the contrast. The dome of the sky on an overcast day is the largest possible light source with the light of the sun being diffused to a relatively even brightness all around, obliterating shadows.

The more nearly a light source approaches a point, that is, the smaller and more compact it is, the better it can be controlled optically. The larger the lighting element becomes, the more difficult it is to control or redirect the light with reflectors or lenses.

LEDs are the most compact light source and being directional allow for the best-controlled optics.

Incandescent lamps and low voltage tungsten halogen lamps have a small filament, hence are suited for precise optical control.

Fluorescent lamps are large, diffuse sources that produce light that is substantially more difficult to control than incandescent sources.

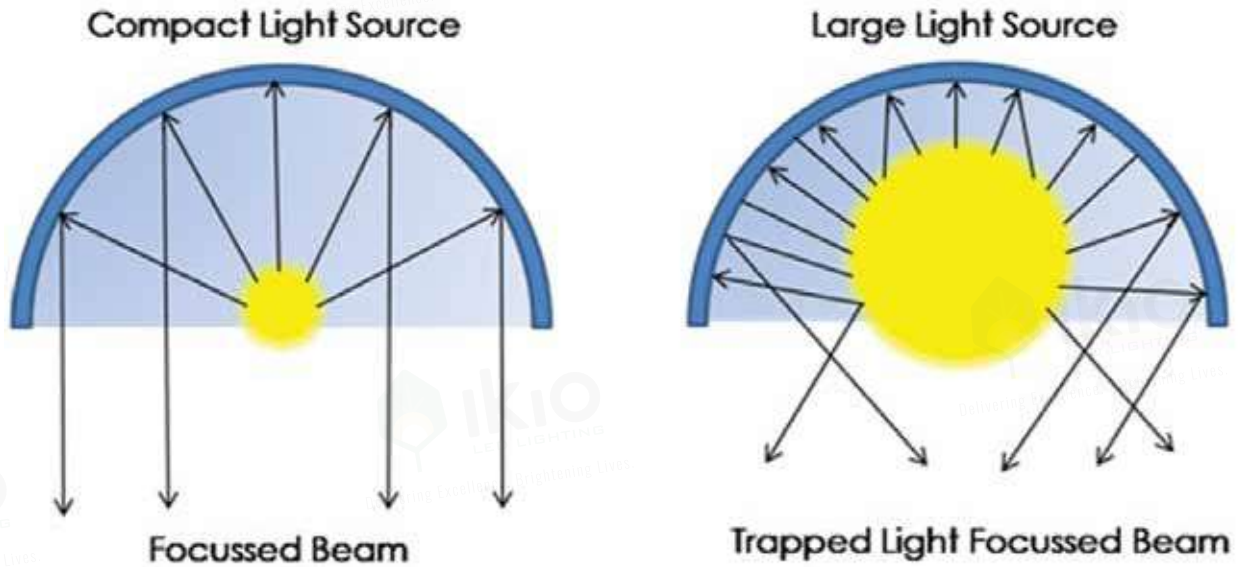

Figure 30. Light Beam from compact and large light sources in identical reflectors

7 » Operation

Lamps differ dramatically, such as different voltages, variation in output and lamp life and the use of auxiliary equipment. All of which affect the suitability of a light source for a particular application. LEDs operate best in colder temperatures which will also allow for increased output and extended life.

The output of Incandescent lamps varies according to the electrical voltage experienced by the lamp. The higher the voltage, the higher the output and the shorter the life. The output

of Fluorescent lamps depends on the ambient temperature: if the temperature is too hot or too cold, output drops below the rated lumens. Extreme temperature variation may also affect the color. Voltage has little effect because of the ballast. Lamp life depends on the number of times the lamp is started.

The output and life of HID lamps vary quite little with temperature or voltage. The operating position affects the output of some lamps.

8 » Ballasts, Transformers & Drivers



Figure 31. (From the left) LED driver, T8 tube ballast and transformer

Electrical auxiliary devices include Transformers, Ballasts and Drivers, which control the electrical voltage and current experienced by a lamp. Except for self-ballasted fluorescent lamps, these devices are mounted in the lighting fixture or remotely, as part of the circuit. Auxiliary devices must generally be compatible with the lamps they control. This is particularly true of ballasts.

Low voltage incandescent lamps require a transformer to reduce the voltage of the electrical circuit. Other incandescent lamps operate without auxiliary devices. Fluorescent and HID lamps require ballasts. LED lamps require a driver.

» Dimming & Switching

All types of light sources can be dimmed, but some are simpler and less costly to dim than others.

LED and Incandescent lamps can be dimmed easily with inexpensive dimmers (low voltage lamps require special dimmers). Dimming generally extends lamp life. Switching has no impact on LED and incandescent lamp life.

Most fluorescent lamps can also be dimmed.

Special ballasts and dimmers are required. The dimming of fluorescent lamps is increasingly popular. Dimming has no impact on the lamp life, but frequent switching will reduce average rated life.

Some HID lamps can be dimmed with expensive, specialized equipment. Dimming of HID is quite rare. HID lamps require time to warm up and cool down with each switching, so frequent switching is a problem.



Figure 32. Effects of dimming LED downlights at various levels



4 Incandescents

1 » Introduction

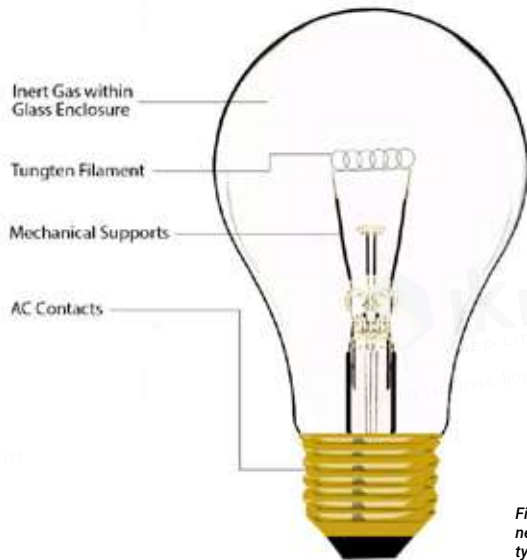

Figure 33. The basic components of an incandescent A type lamp

An incandescent lamp consists of:

- **FILAMENT** (a wire that is heated and glows)
- **BULB** (a glass envelope)
- **BASE**

Lamp designations comprise wattage, a letter indicating the SHAPE, and the maximum diameter of the bulb in eighths of inches. For example, a 150A21 lamp is a 150-watt standard "A" (arbitrary) shape bulb that is $2\frac{1}{8}$ " or $2\frac{5}{8}$ " at its widest part. Lamp catalogs also show maximum overall length (MOL), light center length (LCL), and filament design.

2 » Bases

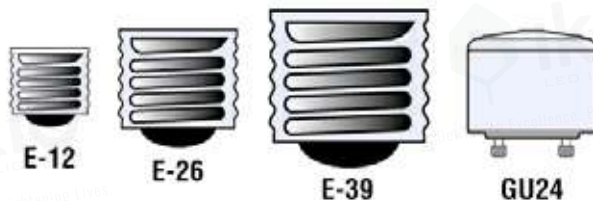

Figure 34. The multiple bases of incandescent lamps

The base provides a means of mounting the lamp, positioning the filament and making the electrical connection. The MEDIUM E-26 screw base is the most often used with mid-range wattage lamps, while the MOGUL E-39 base accommodates large lamps 150

watts and above, and CANDELABRA E-12 base is most often used for small lamps, 25 watts and lower.

A GU24 connector is fitting for compact fluorescent light bulbs (CFL) or LED bulbs that use a bayonet mount-like twist-lock bi-pin connector instead of the E-26 screw fitting used on many incandescent light bulbs. The GU24 fitting maintains the energy efficiency of the light by preventing an occupant from using an incandescent bulb instead of a CFL or LED.

3 » Efficacy

Incandescent lamps produce approximately 16-22 lumens per watt, depending on the design of the lamp. Higher wattage lamps are more efficient than lower wattage ones because the filament burns hotter and therefore brighter. For example, one 100 A19 watt lamp

produces more light (1710 lumens) than four 25 watt lamps (840 lumens); one 150 A 21 lamp gives more light (2780 lumens) than two 75 watt lamps (2360 lumens).

4 » Depreciation

As the filament burns, the tungsten evaporates and is deposited on the inside of the bulb, producing bulb blackening and reducing light transmission

through the bulb wall. Bulb blackening is an indication that the end of lamp life is approaching.

5 » Lamp Life & Output

Light Output of Typical "A" Lamps

Lamps	Lumens	Life
25W	210	2500
40W	460	1500
60W	870	1000
75W	1180	750
100W	1680	750
150W	2850	750

Figure 35. Incandescent lamps: Lamp output vis-a-vis lifespan

Lamp manufacturers can “trade off” incandescent light output for rated life or vice versa. They do this by increasing the thickness of the filament.

The rated life for a typical 25 watt A-lamp is 2500 hours (a mix of very low intensity and long life, for an incandescent source). By contrast, in the A lamp, the mix favors output (2850 lumens) at the expense of life (750 hours). The actual voltage at which the lamp is operated has a major effect on efficacy.

The relationship between wattage, light output and life is shown in the chart below.

6 » Voltage Variation

Most lamps are intended for 120 volts.

When operated under-voltage, the light output will decrease and life will be extended. For instance, life expectancy for a general service lamp doubles when operated 5% below rated voltage. However, light output decreases approximately 15%. Using 130V lamps on 120V circuits results essentially

in making them long life lamps.

Over voltage operating results in a “whiter” light than normal while under voltage operating shifts the color of the light more toward the red end resulting in a warm orangish light.



5

Fluorescent LAMPS

1 » Shapes, Sizes & Wattages

Today's fluorescent lamps are available in a variety of shapes, sizes, and wattages. Fluorescent lamps can be Linear, "U" Shaped, Circular, or Square, and range in length

from 6" to 96". The range in wattage of standard fluorescent lamps can be from 7 watts to 215 watts.

2 » Lamp Components

Glass tubing is coated inside with phosphor

An electronic or magnetic ballast regulates the electric current that stimulates the mercury and argon ions to emit UV light.



Figure 36. The various components of a CFL

A fluorescent lamp is a glass tube coated internally with phosphors (fluorescent material) in which there is a small amount of mercury, an inert gas, and a cathode (electrode) at each end.

Electric current flowing from one cathode to the other creates an arc that excites the mercury, producing mostly non-visible ultraviolet (UV) radiation, which in turn excites the phosphors to produce visible light.

3.1. » Linear Lamps



Figure 37. Types of linear lamps

Tube lights, also known as linear light lamps/ bulbs, are frequently used in office buildings, kitchens, workspaces and commercial installations as well as homes, with varying sizes and brightness levels.

The popularity of fluorescent linear lamps is such that a large number of operators still use them despite the wide availability of more efficient LEDs in the market today. However, these lamps come with their own problems.

A high rate of flicker, lower lifespan and hazardous components like mercury is gradually making this lighting option less desirable to users as better options (like their LED counterparts) are in the markets today with very little difference in their prices.

3.1. » Lamp Designations

Like incandescents, the nominal lamp Watts (exclusive of ballast watts), Shape and Diameter are generally indicated in the following manner:

Example F32T8

F = Fluorescent;
32 = Watts;
T = Tubular in Shape;
8 = Diameter in eighths of an inch or 1"

Additional information following the nomenclature will indicate the color temperature and CRI (Color Rendering

Index).

Example F32T8/830

8 = 80 + CRI;
30 = 3000K Color Temperature

Lamp manufacturers deviate from standard lamp designations. The lamps below have the same characteristics, but designations exclusive to their respective products.

Example:

GE = F32T8/SPX30
Philips = F32T8/TL830
Osram = FO32/830

3.2. » Auxiliary Equipment



Figure 37. A modern ballast for powering four F32T8 office lamps

The ballast provides the necessary voltage and stabilizes the current during operation. Ballasts also consume energy that must be accounted for when determining the efficacy of a particular lighting system.

The ballast must match the electrical characteristics of the lamp in order to function properly. (i.e. the lamp type, wattage and line voltage). For accuracy in calculating lamp efficacy, ballast watts should be added to lamp watts.

Fluorescent lamps are discharge light sources, and like all discharge lamps require a ballast.

3.3. » Performance Characteristics

Lamp Lumen Depreciation (LLD) - Since fluorescent lamps depreciate rapidly during the first 100 hours of operation, definitive evaluation of footcandle levels should be taken only after the lamps are seasoned; that is, burned for at least 100 hours. Initial lumen values are published after 100 hours of operation.

Average Rated Life - Typically the average rated life of an F32T8 is 20,000 hours, based on three hours per start. The fewer

number starts, the longer the life.

Effect of Temperature Variation - Fluorescent lamps are sensitive to ambient temperature. Light output changes when the bulb wall temperature of a lamp is above or below the optimum operating temperature (100 degrees F). When the ambient temperature is below 50 degrees F, low-temperature ballasts are required to start the lamp.

4. » Compact Fluorescent Lamps (CFLs)



Figure 38. CFLs in different shapes and forms

A compact fluorescent lamp (CFL), also called compact fluorescent light, energy-saving light and compact fluorescent tube, is a fluorescent lamp designed to replace an incandescent light bulb; some types fit into light fixtures designed for incandescent bulbs. The lamps use a tube which is curved or folded to fit into the space of an incandescent bulb, and a compact electronic ballast in the base of the lamp.

CFLs are available in a wide range of color temperatures, from 2700 K to 5000 K and in a variety of sizes, shapes, and wattages.

4.1. » Bases



Med Base



Candelabra



GU24

Figure 39. Screw based CFL bases(left and center) and 2 pin base of GU24

Medium screw base CFLs have integral ballasts. Pin based CFLs have either 2 pins or 4 pins.

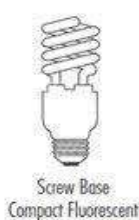

Screw Base Compact Fluorescent



2-tube T4



4-tube T4, T5



Long-tube T5

T- 4 diameter twin-tube two-pin lamps have a starter built into the lamp plug base. They operate on inexpensive reactor ballasts, come in wattages from 5 to 13 watts, and are available for both modular and dedicated systems.

T- 4 and T- 5 diameter quad-tube two-pin lamps have a starter built into the

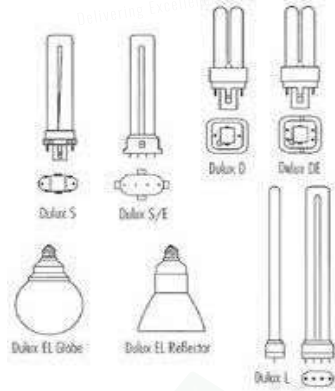

Figure 40. CFLs of different shapes and forms with their respective bases

lamp plug base. They operate on inexpensive reactor ballasts, come in wattages from 5 to 13 watts and are available for both modular and dedicated systems.

Both T- 4 and T- 5 diameter twin-tube and quad-tube lamps are available in four-pin versions that do not contain a starter in the base of the lamp. These lamps are designed primarily for use with electronic ballasts. Four-pin lamps can be dimmed when used with dimming ballasts.

4.2. » Performance Characteristics

It is important to realize that the laboratory environment in which lumen output is measured is quite different from actual conditions. Two conditions that most significantly affect the performance of compact fluorescent lamps are:

- Ambient temperature
- the lamp's burning position

While the compact fluorescent lamp produces rated lumens at 25 degrees C (77F) with the lamp base up, its lumen output drops to 80% of its rated lumens

at 50 degrees C (122F).

In applications where compact fluorescent lamps are mounted in small volume fixtures with a lack of air circulation (such as in lensed downlights), the user should expect that the ambient temperature to be between 40 degrees C and 50 degrees C (104F-122F).

This will reduce the lumen output from the lamp. Some CFL's use an amalgam of mercury, which acts as a "sponge" to either supply or absorb the amount of mercury in the lamp when a change in ambient temperature occurs.



6 » HID LAMPS

1 » How They Work

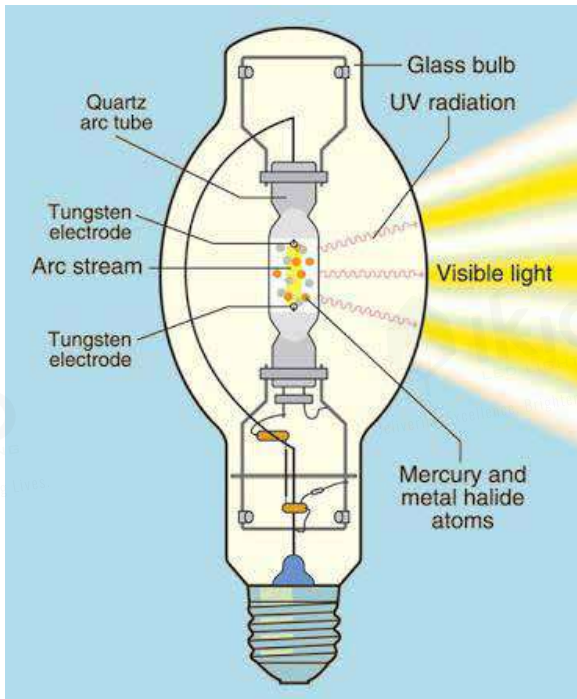

Figure 41. HID lamp technology

High-intensity discharge lamps (HID lamps) are a type of electrical gas-discharge lamp which produces light using an electric arc between tungsten electrodes housed inside a translucent or transparent fused quartz or fused alumina arc tube.

This tube is filled with both gas and metal salts. The gas facilitates the arc's initial strike. Once the arc is started, it heats and evaporates the metal salts forming a plasma, which greatly increases the intensity of light produced by the arc and reduces its power consumption. High-intensity discharge lamps are a type of arc lamp.

Brand new high-intensity discharge lamps make more visible light per unit of electric power consumed than fluorescent and incandescent lamps since a greater proportion of their radiation is visible light in contrast to infrared.

However, the lumen output of HID lighting can deteriorate by up to 70% over 10,000 burning hours.

2 » Mercury Vapor Lamps

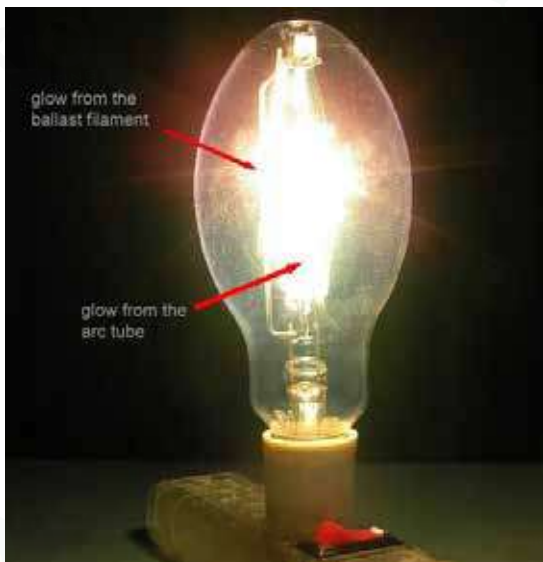

Figure 42. A glowing mercury vapor lamp

Mercury-vapor lamps were the first commercially available HID lamps. Originally they produced a bluish-green light, but more recent versions can produce light with a less pronounced color tint. However, mercury vapor lamps have falling out of favor and being replaced by sodium vapor and metal halide lamps.

3 » Metal Halide Lamp



Figure 43. A 250W MH bulb

Metal-halide (MH) and ceramic metal halide lamps can be made to give off neutral white light useful for applications where normal color appearance is critical, such as TV and movie production, indoor or nighttime sports games, automotive headlamps, and aquarium lighting.



4 » Sodium Vapor Lamp



Figure 44. Low pressure sodium lamps

Low-pressure sodium vapor lamps are extremely efficient. They produce a deep yellow-orange light and have an effective CRI of nearly zero; items viewed under their light appear monochromatic. This makes them particularly effective as photographic safelights.

High-pressure sodium lamps tend to produce a much whiter light, but still with a characteristic orange-pink cast. New color-corrected versions producing a whiter light are now available, but some efficiency is sacrificed for the improved color.

5 » HID Ballast

Like fluorescent lamps, HID lamps require a ballast to start and maintain their arcs. The method used to initially strike the arc varies: mercury vapor lamps and some metal halide lamps are usually started using a third electrode near one of the main electrodes while other lamp styles are usually started using pulses of high voltage.



Figure 45. A35W HID ballast

6 » HID Lamp Uses



Figure 46. Various HID lighting applications

HID lamps are typically used when high levels of light over large areas are required, and when energy efficiency and/or light intensity are desired. These areas include gymnasiums, large public areas, warehouses, movie theaters, football stadiums, outdoor activity areas, roadways, parking lots, and pathways. More recently, HID lamps

have been used in small retail and even residential environments because of advances in reduced lumen bulbs. Ultra-High Performance (UHP) HID lamps are used in LCD or DLP projection TV sets or projection displays as well.

HID lamps have made indoor gardening practical, particularly for plants that require high levels of direct sunlight in their natural habitat; HID lamps, specifically metal halide and high-pressure sodium, are a common light source for indoor gardens. They are also used to reproduce tropical intensity sunlight for indoor aquaria.



7 » HID Lamp Life Cycle

Factors of wear come mostly from on/off cycles versus the total on time. The highest wear occurs when the HID burner is ignited while still hot and before the metallic salts have recrystallized.

At the end of life, many types of high-intensity discharge lamps exhibit a phenomenon known as cycling. These lamps can be started at a relatively low voltage. As they heat up during operation, however, the internal gas pressure within the arc tube rises and a higher voltage is required

to maintain the arc discharge. As a lamp gets older, the voltage necessary to maintain the arc eventually rises to exceed the voltage provided by the electrical ballast. As the lamp heats to this point, the arc fails and the lamp goes out. Eventually, with the arc extinguished, the lamp cools down again, the gas pressure in the arc tube is reduced, and the ballast can once again cause the arc to strike. The effect of this is that the lamp glows for a while and then goes out, repeatedly.



7 » LED LAMPS

1 » Introduction

Unlike incandescent lamps, LEDs are not inherently white light sources. Instead, LEDs emit nearly monochromatic light, making them highly efficient for colored light applications such as traffic lights and exit signs. However, to be used as a general light source, white light is needed. White light can be achieved with LEDs in three ways.

The ability of LED technology to produce high-quality white light with unprecedented energy efficiency is the primary motivation for the intense level of research and development currently

supported by the U.S. Department of Energy. LED lighting technology has improved dramatically over the past 10 years. Improvements in technology have enabled LEDs to achieve the highest lighting efficacies. And LED lighting costs have come down considerably, resulting in significant adoption. Despite this progress, further improvements are both possible and desirable. The technology can be improved in efficiency and other features, such as color quality, light distribution, form factor, and building integration. The manufacturing technology for LED lighting can also be improved to reduce cost and increa

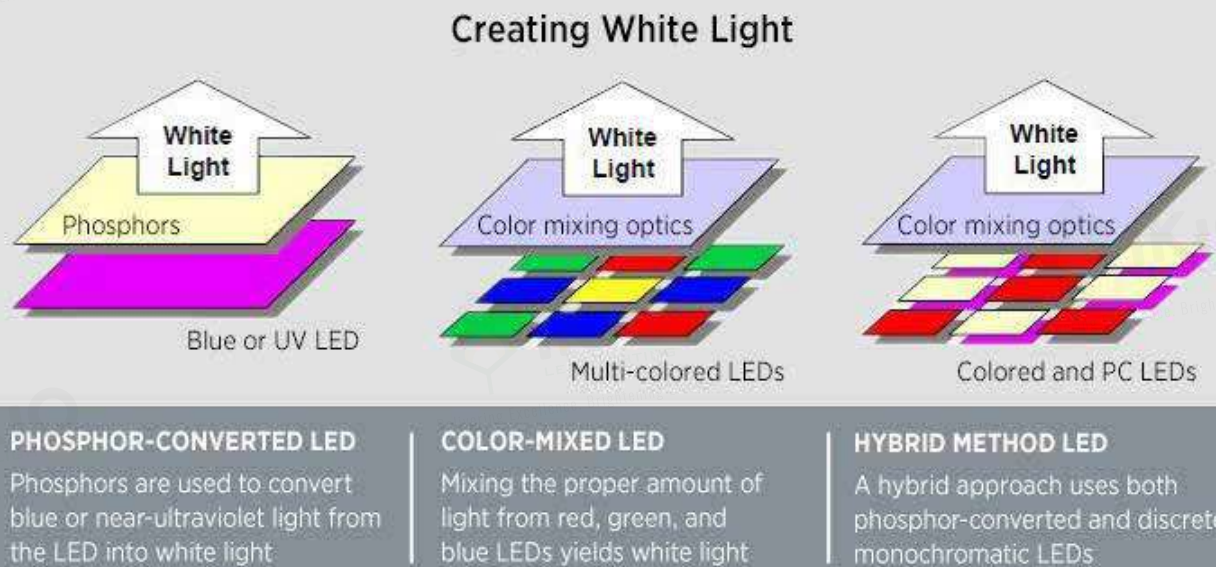

Figure 47. The 3 ways used by LEDs to produce white light

2 » Lamp Designations

Top five benefits Americans will realize by meeting DOE goals for LED efficacy

1. Enormous energy savings of 5.1 quads annually by 2035, cutting U.S. business and homeowner electricity bills by \$50 billion a year and enhancing energy security
2. Scientific progress and technological advances on semiconductors, phosphor materials, quantum dots, power supplies, and optical materials with crossovers into other technology.
3. Better LED products that deliver improved lighting quality, longevity, and reliability, as well as enhanced services.
4. Lower first costs for LED lighting products, which, in turn, will encourage change-out of the existing lighting stock to more efficient devices.
5. Stronger positioning of domestic LED manufacturers who produce high-value, high-brightness LEDs.

Impressive gains in the efficacy of LED (light-emitting diode) lighting technology have been realized in the past decade, as evidenced by the high-performing products now gaining share in growing numbers of lighting market niches.

Energy efficiency has motivated DOE investment in solid-state lighting (SSL) technology since the inception of the 'Efficiency First' program.

Figure 47. The 3 ways used by LEDs to produce white light



3 » LED LAMP COMPONENTS

3.1 » LED Recessed Downlight

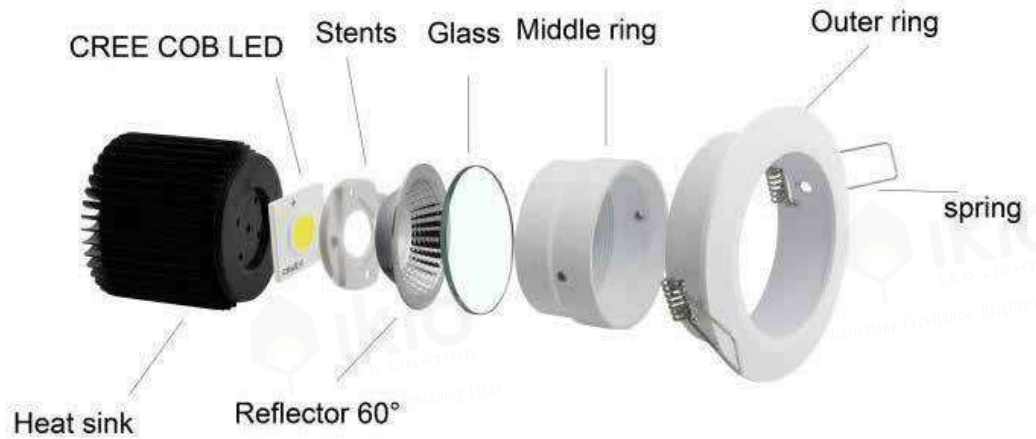

Figure 48. Components of a typical LED downlight with CREE COB LED chipset

3.2 » LED Panel Light

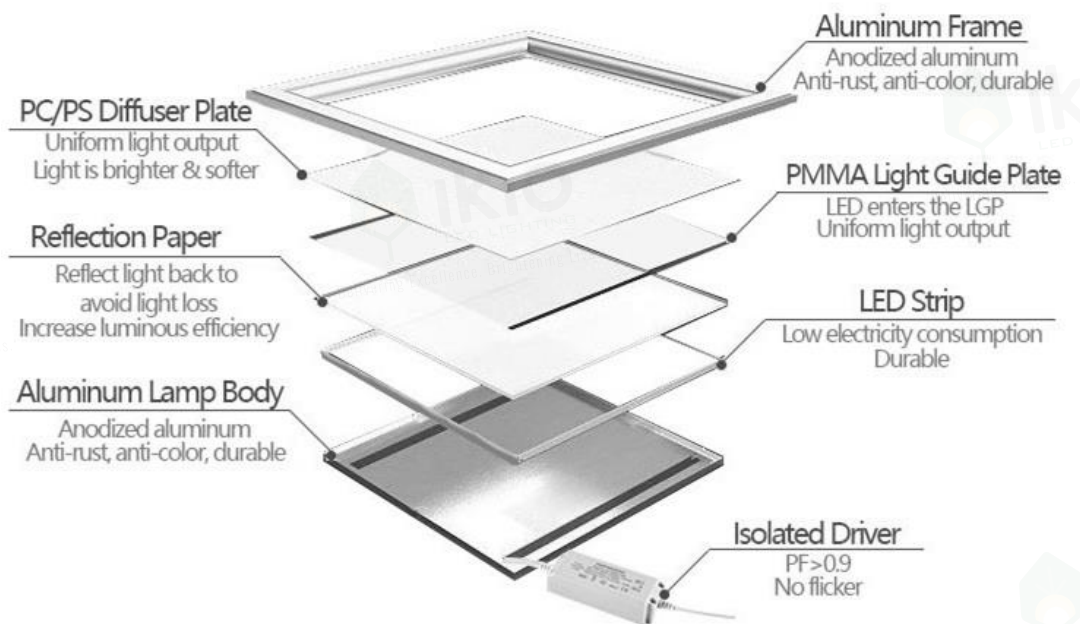

Figure 49. Components of a typical edge-lit panel light

3.3 » LED Strip Light

LED EMITTERS

Common LED types include 2835 and 5050 SMD. The light color and quality are determined by the individual LED emitters.

FLEXIBLE CIRCUITBOARD

The LEDs and components are mounted on a flexible circuitboard, allowing for installation and mounting on curved and uneven surfaces.

CUTLINE AND CONNECTION

Cut the LED strips using just a pair of scissors to your desired length. The copper ovals act as the electrical connection points where power is fed through.

ADHESIVE BACKING

Peel-and-stick adhesive on the back side allows for quick and easy installation in a wide variety of locations.

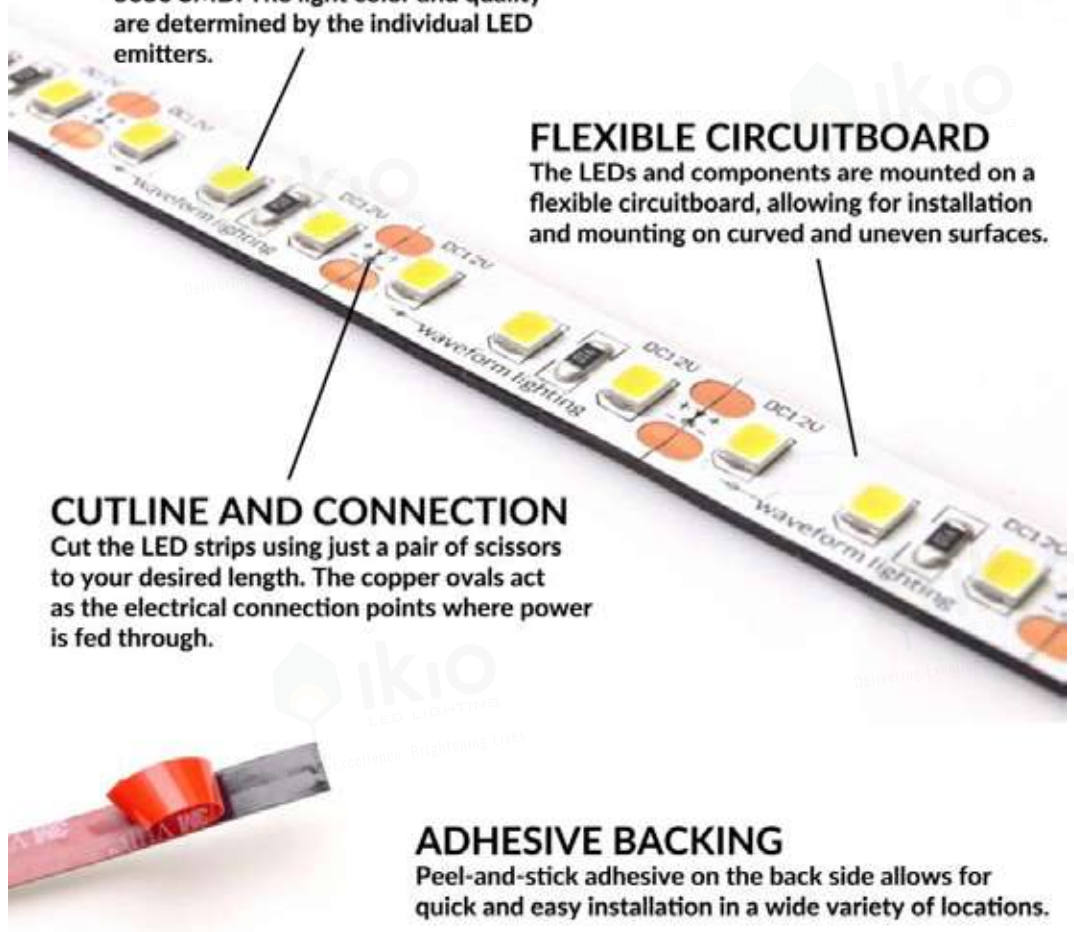

Figure 50. Components of a typical LED strip light







8



COMPARATIVE ANALYSIS



1 » A-Series Light Bulbs

	Incandescent	Halogen	CFL	LED
				
Annual cost of operation/bulb*	\$7.01	\$5.05	\$1.75	\$1.19
Lumens per watt	15	25	60	72
Percent more efficient than incandescent	-	28%	75%	83%
Rated bulb life*	1.4 years (1,000 hours)	4.2 years (3,000 hours)	14 years (10,000 hours)	34 years (25,000 hours)
Instant on	yes	yes	most	yes
Dimmable	yes	yes	some**	most**
Cold tolerant	yes	yes	somewhat	yes
Contains Mercury	no	no	yes	no

2 » Lube Lights

	LED TUBES	Fluorescent Tubes
		
Lifespan	7,000-15,000 hours	50,000 hours
Efficacy	50-110 lm/W	120-175 lm/W
Comfort	Ergonomic with very little flicker	not ergonomic, lighting is drab and most lamps flicker
Materials	no hazardous materials	Contains hazardous materials like mercury
switching	Doesn't effect lifespan	Reduces lifespan
CRI	80+ or 90+	50 (basic type) 90 (multi phosphor type)

9



INDUSTRIAL LED LIGHTS

1 » High Bays



Figure 51. High bay lighting in a warehouse

A high bay light is usually defined as a light intended for use in a ceiling ranging from 20-40 feet in height from the floor. A high bay ceiling is usually found in industrial and some commercial spaces.

LED high bays are luminaire designed to provide highly efficient, undisrupted and uniform lighting for industrial application and are an ideal solution for higher mounting heights, high-temperature application, and special heavy-duty industries. It enables a safe

working environment with leading specifications and comfortable light. At the same time, it lowers the overall maintenance cost. Robustness and aesthetics make high bay fixtures a perfect solution for versatile applications.

Applications:

Arena and Sports, Food processing units (NSF grade fixtures only)
Manufacturing, Warehouses,
Airports, etc.

Types of Fixtures:



Figure 52. (From the left) LED UFO Highbay, NSF Grade UFO Highbay, and Linear Highbay

2 » Low Bays

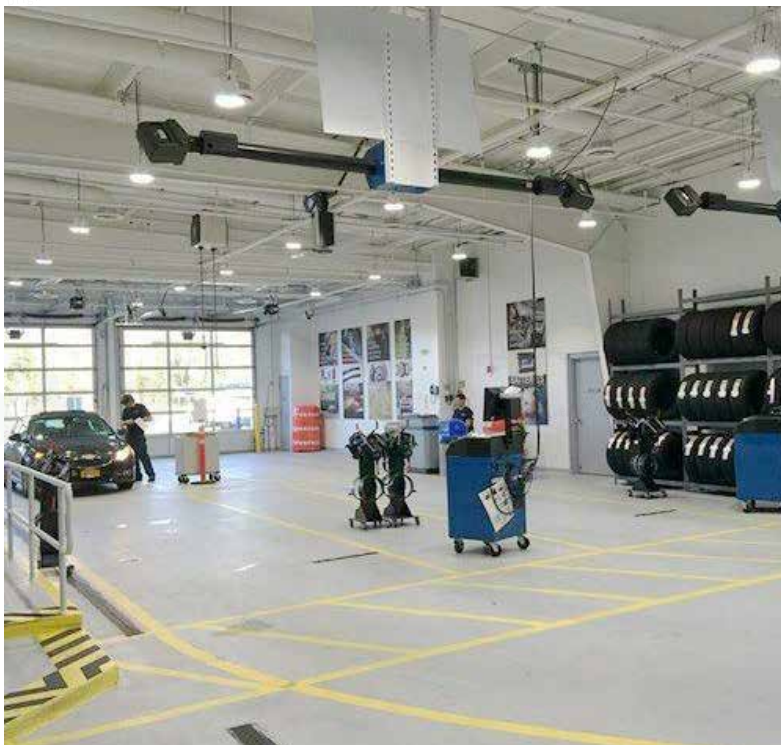

Figure 53. Low bay lighting in an auto service center

A low bay light is usually defined as a light intended for use in a ceiling under 20 feet in height from the floor. A low bay ceiling is the most common type of ceiling commonly seen in homes, most retail businesses, and public buildings.

LED Lowbay luminaires are over 70% efficient than their Metal Halide counterparts. They illuminate work areas, creating a brighter and better work, retail or sporting environment. They can be equipped with motion detection functions to enhance their control and save more energy.

These fixtures are low-maintenance and usually easy to install.

Applications:

Industrial workspaces, Open areas, Warehouses, Retail stores, Stadiums, etc.

3 » Retrofit Lights

Retrofitting is a term often used when converting older, outdated lighting technologies such as fluorescent, CFL and HID (metal halide) to newer energy-efficient technology, like a LED system.

LED Retrofit lamps use better lighting technology to increase energy efficiency and the quality of light in the facility. The most used LED retrofit option in the US today are LED Tube lights that are used for upgrading from their fluorescent counterparts.

A retrofit kit is an all in one system that allows for easy, quick installation of LED lighting. Generally, a retrofit kit includes brackets, sockets, wiring,

screws and fasteners: most everything needed to facilitate a quick and easy install. We are pleased to be using high quality Canadian made products.

Applications:

Retrofitting existing lighting systems.

Types of Retrofit Lamps:



Figure 54. (From the left IKIO's Retrofit low bay lamp, high bay lamp and corn bulb

4 » Floodlights



Figure 55. Stadium floodlights in action

A floodlight is a broad-beamed, high-intensity artificial light. They are often used to illuminate facades, outdoors and playing fields while an outdoor sports event is being held during low-light conditions. More focused kinds are often used as a stage lighting instrument in live performances such as concerts and plays.

LED Floodlights deliver high lumen efficacy, long lifetimes and reliable designs. They are perfect for replacing conventional lighting technologies and enabling intelligent lighting control while retaining the same electrical installation and poles.

Applications:

Architectural lighting, Landscape lighting, Billboard lighting, Parking area lighting, Security

lighting, Outdoor sports and general area illumination.

Types of Retrofit Lamps:



Figure 56. (From the left)LED stadium floodlight, architectural floodlight and ultra slim floodlight

5 » Area Luminaires



Figure 57. Area Luminaires in a parking lot

Illuminating large outdoor areas require high levels of light. This is where area luminaires come in. HID (high-intensity discharge) lamps were the golden standard for illuminating wide areas. But it comes with certain flaws

LED Floodlights consume around 30 percent less energy than traditional lighting technologies. For high mast lighting applications, this is a key advantage – especially for remote assemblies that operate on generators or batteries. Plus, they can withstand colder temperatures without a compromise in lighting performance is an advantage in winter weather conditions. In comparison to HIDs, LEDs do not require a long warm-up period. They can provide instant illumination without affecting light performance.

Applications:

Parking lot, street and building perimeter lighting. It can also be used in flood or area lighting.

Types of Retrofit Lamps:



Figure 58. (From the left) IKIO's Amparo and Canopus area luminaires

6 » High Mast Lights



Figure 59. High mast lighting in an airport

High-mast lighting is a tall pole with lighting attached to the top pointing towards the ground. It is used at sites requiring lighting over a large area. The pole that the lighting is mounted on is generally at least 30 m (98 ft) tall, while the lighting consists of a luminaire ring surrounding the pole with one or several independent lighting fixtures mounted around it. Most units have four, six or eight lights in the ring, with three, five, ten, twelve and sixteen lights used in rarer instances.

While most high-mast lights are high-pressure sodium, other types such as mercury vapor and metal halide are also used. LED high mast light fixtures, provide excellent efficacies for large areas or sites requiring illumination because of how they generate light and how they distribute light. LED fixtures commonly utilize multi-point sources. When you compare this to the way most

HID fixtures distribute light (with a single bulb and reflectors within the fixture), the result is light that is more evenly distributed across a given area.

Applications:

This type of outdoor lighting is often used by municipalities, ports, municipal authorities, and in parking lots of large venues such as stadiums and sports facilities.



Figure 60. IKIO's Hexacule LED high mast light

7 » Canopy Lights



Figure 55. Stadium floodlights in action

Figure 61. LED Canopy lights at a gas station

Bright and clear canopy lighting increases a sense of safety. Canopy lighting solutions deliver high vertical lighting levels, increasing customers' sense of safety and comfort which, in turn, drives brand loyalty.

A switch to LED canopy lighting can save up to 90% energy compared to conventional solutions. Savings can be optimized even further by adding smart energy management systems that allow light levels optimization and maintenance planning.

Applications:

Canopies of Garages, Gas Stations and Parking Structures.



Figure 62. IKIO's Ortega and Parko canopy lights

» Wall Packs



Figure 63. Wall pack lighting in warehouse exterior

Wall pack lights or exterior building lights are terms that describe the outdoor lighting that is commonly mounted on the outside facing walls of buildings. This type of exterior lighting is generally used to provide illumination to ground areas frequented by vehicles and pedestrians. They also function well as an added layer of security for property owners.

A typical outdoor wall pack light is likely to be a sodium vapor light. Sodium vapor lights are the ones that tend to be very deep yellow (or orange) in hue. Low-pressure sodium vapor lights produce a monochrome emission that tends to render color very poorly in exchange for relatively good energy efficiency for a legacy bulb technology.

Modern industrial LED wall packs tend to provide high efficiency, low maintenance costs and better light output in comparison to the legacy systems. Additionally, they have options of including motion sensors and photo sensors for enhanced light controls and better energy savings.

Applications:

Ideal for outdoor applications like Security, Walkway and Perimeter lighting.

Types of fixtures:



Figure 64. An illustration depicting the light spread of a full-cut off wall pack light

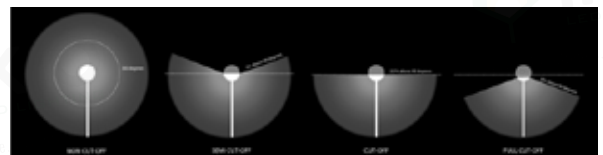

Figure 65. Illustration explaining light shielding in luminaires

Most Wall Packs out there in the markets today are usually of 3 kinds, distinguished by their light-shielding:

- Cut off
- Semi-cut off
- Full-cut off



Figure 66. (From the left) IKIO's LED Wall packs: Torin, Olof (semi cut-off), Lupos (directional) and Osvin (full cut-off)



» Emergency Power Packs

Emergency Power packs allow any light fixture to be converted to an emergency light. In the event of a power failure, the fixture automatically derives power from the battery pack.

These are meant for fixtures that have external drivers. They are usually ETL component rated and come with specifications that mention the power ranges of the fixtures and hours of illumination that they can support.



Figure 67. IKIO's Emergency Power Pack for for 11-28 W backup illumination for 90 -120 min

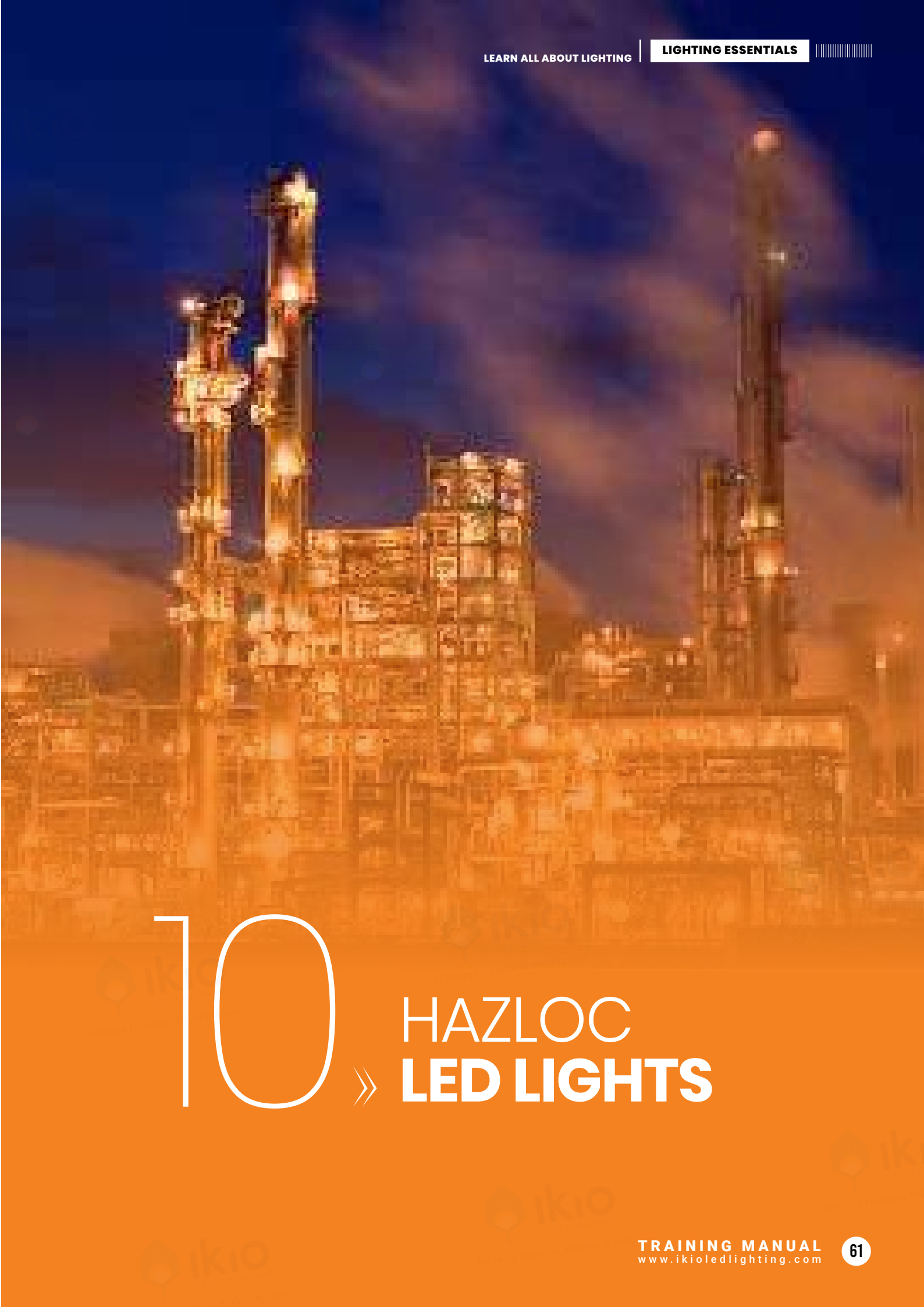

10 » HAZLOC LED LIGHTS



1 » Introduction



Figure 68. Power grids and oil rigs are major users of explosion-proof lighting

Lighting is an integral part of any business. And any business that operates in classified and hazardous environments, it is important to use Explosion-proof lighting. These harsh and hazardous environments potentially contain explosive gases and vapors which increase the risks from explosions which may occur if proper precautions aren't in place.

Explosion-proof lights also called HazLoc or

Hazard Location lighting is designed for use in areas where explosive and flammable gases such as hydrogen, methane, propane, and other hydrocarbons are present. Working in confined spaces or areas exposed to such environments can be very dangerous and hence this kind of lighting is imperative for such locations for the safety of workers and businesses.

2 » The Unique Factors

Explosion Proof LED Lights are one of a kind fixtures that make businesses not just safe from accidents but safe from unnecessary expenses on maintenance and energy costs.

1. Explosion Proof Design

Standard light fixtures are usually composed of a design that exposes the bulb, contacts, wiring, and switches to the atmosphere. Hence, spark from a loose contact or movement of the switch or even the heat from the bulb is enough to ignite a flammable environment. But, in the case of Explosion-proof lights, the components

are encased to prevent potential sparks or flames from escaping the internal housing.

2. Durable & Tough

Given the rugged build of the explosion-proof light fixtures with sturdier materials, they offer a high degree of durability in comparison to standard light fixtures, as they can withstand harsher working environments. This makes them a better option for operators as it will not be as easily damaged as standard light fixtures and would reduce maintenance and refurbishing costs.

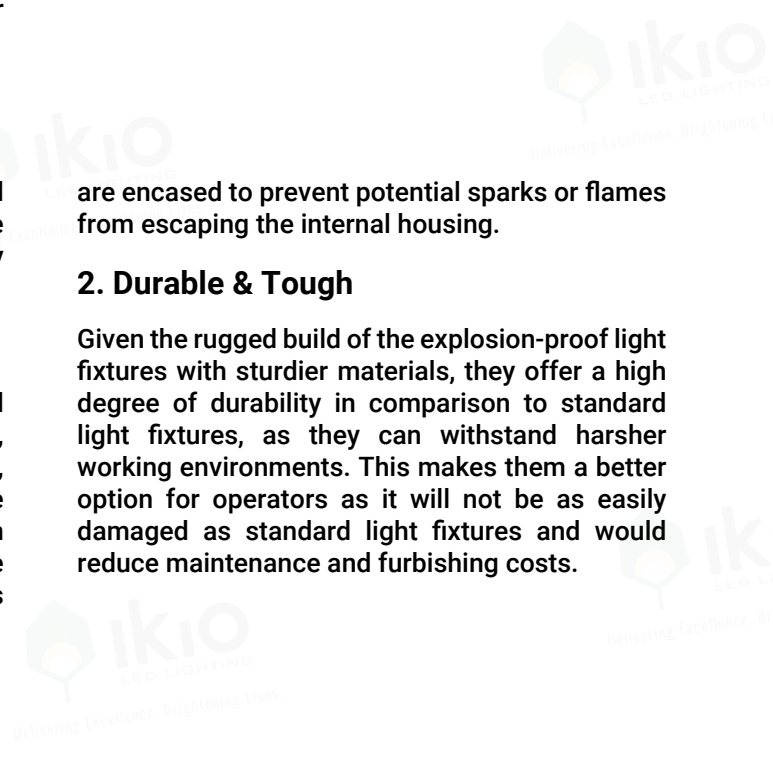

3. Allows Greater Mobility

Explosion-proof LED lights are built with a strong frame and thicker tempered glass lenses, making them highly resistant to vibrations. This durable design allows the transportation of these lights from one place to another by forklifts or other machines without the risk of damage or malfunction, thus making them more portable. This feature makes it an ideal choice for operators who require mobile illumination.

4. High Efficiency

Explosion Proof LED lights are extremely energy efficient. They use more than 90% of the energy to produce light and have near-zero heat or conversion loss to account for, which means that

they use a lot less power to function. Organizations save on-site energy from portable generators and other in-situ sources, providing more sustainable and profitable operations. In other words, you'll save money running explosion proof LEDs for the same or better light output your current explosion-proof lamps give you.

5. Flexible Options

Modern Explosion Proof LED lights are offered in modular designs and multiple mounting options to allow multitudes of options in their application. They allow light outputs to be easily increased or lowered to match required light levels or adapt to existing access points, all while saving energy and money.

3 » High Bays

The explosion-proof LED high bays are a Hazloc family of fixtures that are suitable for use in a wide range of indoor and outdoor applications. They are usually available in eight to ten mounting options and multiple power options. This versatile family of fixtures can be used for ceiling, pendant, wall and surface applications, and replace traditional HID fixtures ranging from 100W to over 400W.



Figure 69. IKIO's Explosion Proof High bays (from the left): Dominus, Enzo and Ergo.

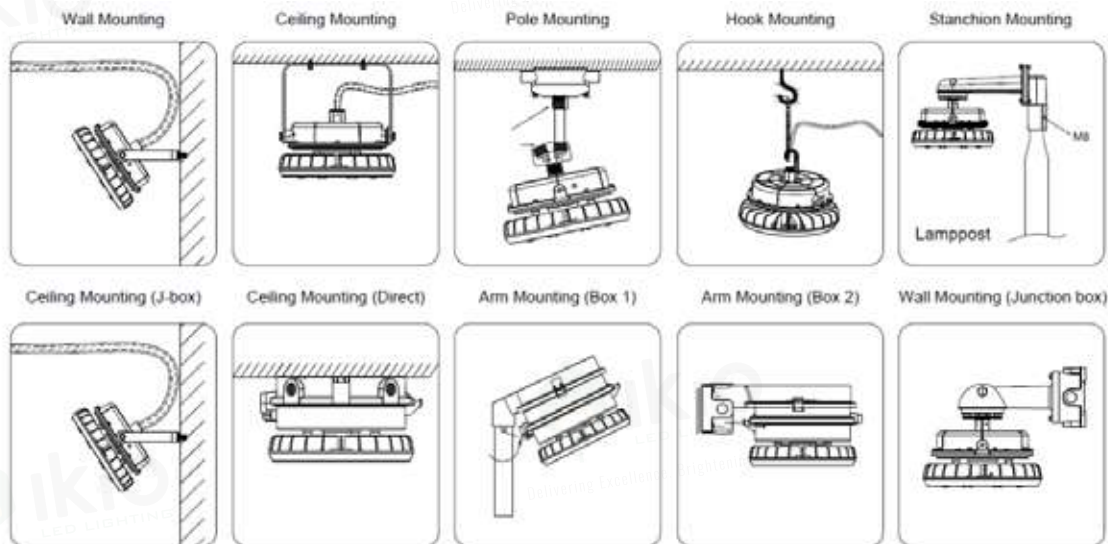

Figure 70. The ten mounting options of Dominus LED high bay

These LED luminaires are compact & low weight and are safe and easy to use in harsh and hazardous locations where flammable or explosive vapors or gases are present. They are an ideal Lighting solution where long life and low maintenance are desired.

General fixture types: UFO high bay and Linear

High bay.

Applications: Industries for oil and gas, LNG and chemicals, ocean, marine and aerospace fields, metal treatment plants, food and alcohol industries, and other high humidity, high dust, high temperature, and high vapor locations.

4 » Area Lights



Figure 71. IK10 Trabuco Area Light

Explosion Proof LED Area Lights are a family of lightweight, explosion-proof luminaires for lighting large areas. They are designed for installation in Class I, II and III hazardous environments. They provide all the general

qualities of LED fixtures like high energy efficiency, superior lighting quality, and longer operating life. Like all explosion-proof luminaires, they are manufactured in accordance with the European Directive (ATEX) and IECEx standards. Being an LED luminaire, they also offer a high color rendition index compared to high-pressure sodium lamps.

Applications: Oil refineries and gas stations, oil and gasoline loading docks, distilleries and other hazardous outdoor locations.

5 » Jelly Jar Lights



Figure 72. IK10 Vaso Jelly Jar light

LED Jelly jar lights are a specific type of explosion and industrial HazLoc fixtures that are sealed, gasketed, and rated for damp or wet locations. Jelly jar vapor-proof fixtures are called this because their housing resembles a Mason jar, yet the protective outer cage protects

them from smashing or breaking.

Applications: Industries for oil and gas, LNG and chemicals, ocean platform operational facilities, marine and aerospace fields, metal smelting, foundry and fabrication plants, food and alcohol industries, flour and fine particle production and storage facilities and other high humidity, high dust, high temperature, and high vapor locations.

6 » Exit Signs



HazLoc Exit Signs are suitable for locations deemed hazardous due to the presence of flammable vapors or gases, or combustible dust. They provide distinct, highly visible

exit marking to indicate safe egress areas during power outages and other emergencies.

Applications: Manufacturing plants, chemical plants, paint shops, oil refineries, gas stations, industrial facilities, warehouses, processing plants and other Class I, Division 2 hazardous locations

3 » Trouble Work Lights Bays



Figure 73. Work lights in use at a construction site



Figure 74. IK10 Lantorch Trouble Work Light

Trouble work lights are generally used for temporary lighting of workshops, garages and other work areas requiring additional lighting. It is composed of a flexible wire, high heat-resistant bulb collar, grounded metal guard, a handle, and hooks. Hazloc LED Portable Guarded Trouble Work Lights are flameproof handheld work site luminaire for task or general illumination in small and confined hazardous spaces. Given their use of LEDs as a light source, they are more compact, don't heat up and of course, are far more efficient than the work lights that use legacy lamps.

Applications: Manufacturing plants, chemical plants, paint shops, oil refineries, gas stations, industrial facilities, warehouses, processing plants and other Class I, II and III hazardous locations.

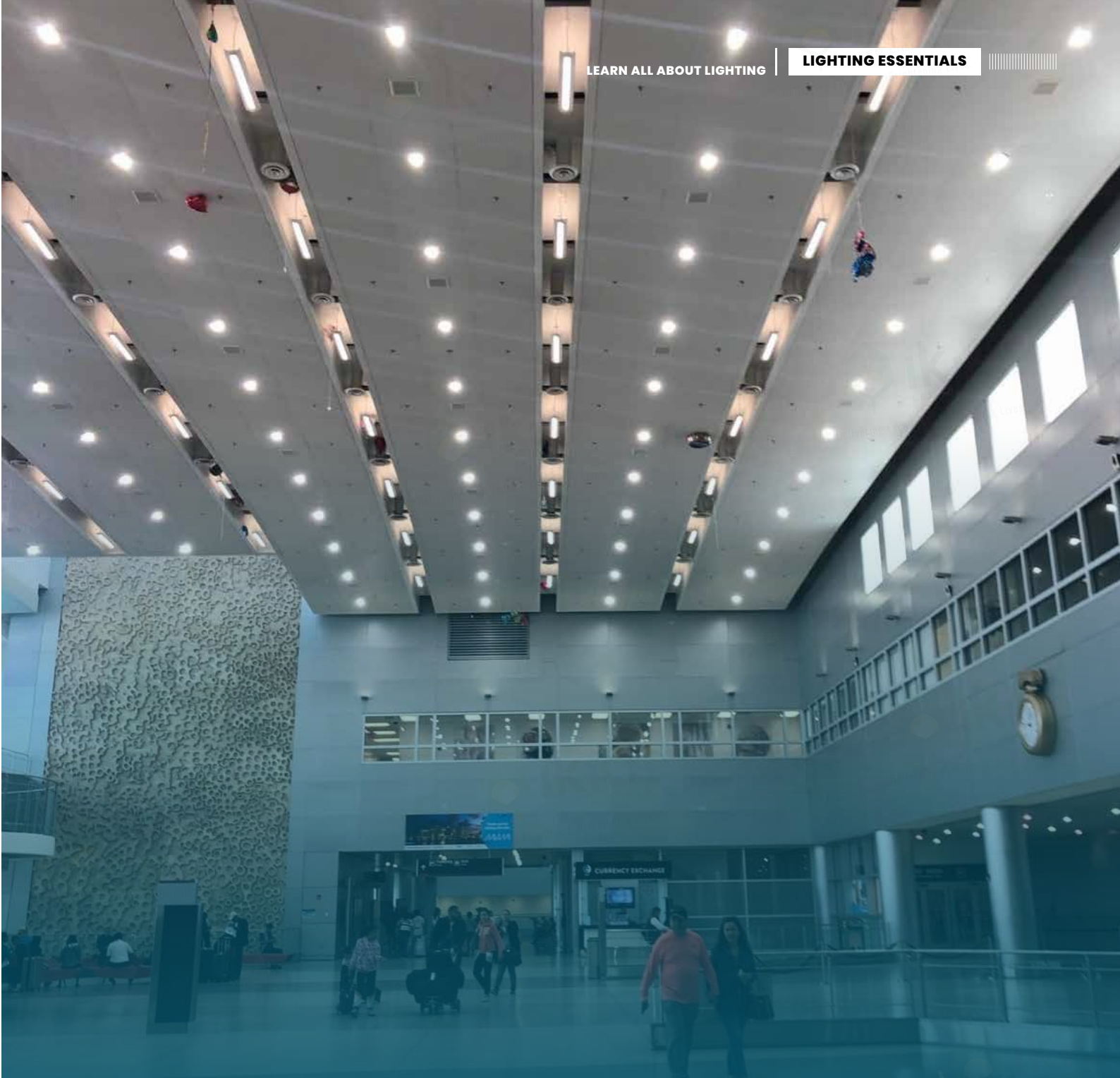

COMMERCIAL » LED LIGHTS

1 » Liner Lamps/Tube Lights



Figure 74. LED Tubes raise the bar in lighting efficiency and comfort by meeting all commercial lighting standards.

One of the most common ways to illuminate large indoor spaces like warehouses, schools and offices has been the linear fluorescent Tube. Given that this has been the trend for several decades, most facilities are already configured with recessed troffers that accommodate mostly T5, T8 and T12 fluorescent lamps. When an area is already lit with fluorescent fixtures, upgrading to compatible LED tube lights is an affordable solution.

These lamps are one of America's most-used retrofit lamps. They integrate an LED light source into a traditional fluorescent tube lamp form. LED tubes raise the bar in lighting efficiency and comfort by meeting all commercial lighting standards. They don't flicker or cause glare. They are also 100% instant switch on lights and have a high color consistency and uniform visual appearance. They are a mercury-free alternative to traditional fluorescent tubes which has the potential to contribute towards a facility's green credentials. These lamps are best suited for users with a limited budget who are looking to upgrade to reap the benefits of LEDs without changing their existing lighting infrastructure.

Applications: Indoor applications in work areas, covered car parks, warehouses, signage, transport and distribution hubs.

Lamp types:

Apart from the major tube light classifications based on its diameter, T5, T8, and T12, there are 4 types of LED Tubes based on their drivers: Type A, Type B, Type C and Type A&B

TYPE A LED Tubes (Ballast Driven)

Sometimes referred to as plug and play, the Type A LED Tubes directly replace linear fluorescent lamps. They don't require rewiring and hence can easily be installed/replaced by the user without the services of an electrician. However, it is also important to know that not all Type A LED tubes are compatible with all existing ballasts. Refer to the manufacturer's terms of use to make sure the same.

Benefits:

- When upfront cost is the top priority
- If the existing system (ballasts) are relatively new (less than 10 years old)
- The user doesn't want to invest a lot in a leased property but wants to reduce their electric bill.
- If the user wants the ability to switch back to the original Linear Fluorescent or CFL lamps.

TYPE B LED Tubes (Ballast Bypass/Direct Wire)

Type B LED Tubes are essentially ballast bypass lamps. They are also called line voltage lamps.

They have an internal driver built into the lamp and require to be directly wired to the power source bypassing the fluorescent ballast. They are the most popular type as they are less expensive compared to others and reduce maintenance costs by eliminating the ballast.

Benefits:

- When the user wants the lowest cost of ownership
- If the existing ballasts are effectively at the end of their life (10 years or greater) or the user is experiencing significant power failures
- When the user doesn't want to worry about ballast compatibility, for instance, in a large installation there would be a variety of ballast types/brands, and all in different life cycles
- When users don't want to rely on an electrician to repair the lights in the future. With the ballast removed, the user only replaces the lamps during maintenance, hence eliminating the need for a ballast.
- When the user is buying an "LED Ready" fixture
- When the user has no chance of re-lamping with the old technology.

TYPE C LED Tubes (External Driver)

Type C LED Tubes work with external drivers. These lamps need a fixture mount driver and their installation happens in the same way as fluorescent

lamps and ballasts. They come with programmable outputs, dimming options and a longer lifespan.

Benefits:

- When rebates are driving the decision to upgrade
- When the user has no chance of re-lamping with the old technology.
- When upfront costs are not an issue

TYPE A&B LED Tubes (Dual Mode Internal Driver)

Besides the 3 types of LED tubes, Type A, Type B, and Type C, there is also a type of hybrid LED tubes that are developed as Type A and Type B, also known as Type A+B. A Hybrid LED tube is a combination of Type "A" and Type "B" tubes. They are sometimes also called Type D LED tubes.

This LED tube type can work with the existing fluorescent ballast or can operate without the ballast. This is an excellent choice for those installations that want to use the fast installation method using the ballasts but have a backup plan if the ballast is not compatible, as not all manufacturers' ballasts are compatible. Most manufacturers suggest reviewing their list of compatible ballast before installing Type A&B LED tubes.

2 » Refrigeration Lights



Figure 75. Refrigeration technologies provide sharp and lively light with high CRI



Figure 76. IKIO Frizo LED Refrigeration Light

LED refrigeration lighting offers grocery stores significant savings on energy, a reduction in operating costs while improving the shopping experience. LED refrigeration lighting and LED cooler lights are made using specially designed optics that correctly focuses on a high concentration of light output that is evenly spread. Today's advanced LED refrigeration lighting technologies provide sharp and lively light with

high CRI that produces eye-catching refrigeration and food freezers.

Even when creating an identical volume of light as traditional refrigeration lights, LED refrigeration lights use significantly fewer amounts of energy. The average supermarket sees a reduction in 38% of total energy operating costs a year. Now imagine if you have a group or chain of stores, this could save you hundreds of thousands of dollars a year. Additionally, LED refrigeration lighting releases less heat compared to customary refrigeration lighting. This reduction in heat lessens the strain on the refrigeration's cooling system thus adding extending the life of your refrigerators, freezers, and coolers.

Applications: Refrigeration Area & Cold Storages

3 » Magnetic Strip Kits

These are the market's easiest fluorescent-to-LED conversion kit that reduces lighting costs by up to 85%. They are a direct replacement for inefficient fluorescent tubes. In just a few simple steps, existing recessed and surface mounted troffers can be converted to energy-efficient, long-lasting LED light while preserving the look of the space with the use of these economical kits.



Figure 77. IKIO Striza Magnetic Strip Kit

4 » Linear Low Bays



Figure 75. Refrigeration technologies provide sharp and lively light with high CRI

LED Linear Low Bays are highly efficient retrofit replacement for fluorescent tube fittings. They are a perfect combination of a traditional low bay design with cutting-edge LED technology and efficient performance. UFIT is perfect for indoor environments including warehouses, factories, storage facilities, educational spaces and retail applications.

Applications: indoor environments including warehouses, factories, storage facilities, educational spaces and retail applications.



Figure 78. An LED Linear Low bay from a leading manufacturer

5 » Refrigeration Lights



Figure 79. Tri-proof luminaires are vandal resistant and see major use in underground parking areas



Figure 80. IKIO Defenza Tri-proof luminaire

Tri-proof lights are waterproof, dustproof, and corrosion-proof. They are made with special corrosion-proof materials and silicone sealing ring to realize protection

requirements for the fixtures. From the ends where the cable comes out, there are with waterproof PG connectors for a seamless connection, it secures the cable and keeps water and dust from entering. LED tri-proof lights are specially designed for rough conditions and also can withstand high pressure. The IP rating for tri-proof light is normally IP65, IP66, some can even reach IP68 and IP69.

Applications: Commercial applications like warehouse lighting, parking garage lighting, supermarket lighting, outdoor areas, pedestrian bridges, awning backlighting, and more.

6 » Troffers



Figure 81. Troffers typically fit into a modular recessed ceiling grid



Figure 82. IKIO Flamingo Architectural Troffer is an uplighter troffer perfect for work areas

A troffer is a rectangular or square light fixture that typically fits into a modular dropped ceiling grid, often described as recessed. Historically, troffer fixtures have been designed to accommodate standard fluorescent lamps like T12 or T8 bulbs. However, now troffer lighting is

available in LED.

LED troffers can significantly reduce the consumption of electricity for a building or facility. If we look at specific wattages, a typical 2x4 fluorescent troffer light can utilize up to 160 watts per fixture. If we examine the same fixture utilizing LED technology instead, we see that the same fixture utilizes between 30 and 50 watts per fixture. This results in a 50% to 80% reduction in cost savings just by making the switch to LED.

Fixture Types: CCT & power tunable troffers, Retrofit troffers and Uplighter troffers.

Applications: Lighting indoors of offices, work areas, educational facilities, and other commercial spaces.

7 » Panel Lights



Figure 83. LED Panel lights are widely used in office settings because of their low profile designs

Traditional fluorescent panel lighting is often dim and unsightly, requiring panel removal to change bulbs and clean out dust and insects. Flat-panel LED lighting yields a beautiful, skylight appearance for up to 50,000 hours while using half the power of traditional fluorescent bulbs. Less maintenance, lower cost, and enhanced appearance clearly make LED lighting the better option. However, deciding to use Panel LED lighting is only the first step. They are available in backlit and edge-lit variants.

Applications: Warehouses, offices, schools, and hospitals.

Fixture Types: General Panel lights, CCT & Power Tunable Panel lights, and RGBW Panel Lights.

7.1 » Edge-Lit Panel Lights



Figure 84. IKIO Astral Edge lit panel light

The lighting source of an edge-lit panel is found along the perimeter of the panel, which typically has a protective aluminum covering.

The light produced on the edges is then dispersed towards the center, producing a completely even, shadow-less light distribution. The slim panels allow for various methods of installation, including the ability to be suspended, recessed, or mounted. This variability makes for a sophisticated appearance depending on the space in which they are being used.

7.2 » Back-Lit Panel Lights



Figure 85. IKIO Delphi power tunable backlit panel light

The light source for backlit panels is located at the back of the panel. Light is distributed away from the source across the panel and is evenly distributed into space. Backlit panels are inevitably thicker to achieve a uniform dispersion of light, and therefore the options for installation are limited.

Although backlit panels may not have the slim and refined appearance of an edge-lit panel, it's important to note their monetary benefits. They cost less than edge-lit panels, meaning less money spent in the initial investment. In conclusion, when users are looking for a more aesthetically pleasing, shadow-less light and are not opposed to footing a higher initial investment, edge-lit panels are an excellent choice. For a less expensive but more efficient and practical source of lighting, backlit panels are a great option.



12

» Horticulture » **LED LIGHTS**

1 » Introduction

One of the major elements which make horticulture functional is Grow lights. Grow lights allow horticulture professionals to grow plants in controlled environments sans the interferences from the vagaries of nature.



Figure 87. HPS grow lights at a lettuce farm

In the initial days of horticulture, HID lamps were the go-to lights. They were power guzzlers in the real sense. Their bad reputation was further fueled by the exorbitant amount of heat that they generated, which apart from causing a lot of safety issues, had the tendency to damage the very plants that were being grown. They were eventually replaced with a bit more efficient fluorescent lamps.

But, the further advent of technology introduced LED Grow lights. Its use has increased the efficiency of growing food by manifold. Their energy efficiency, increased spectrum control, lifespan and low heat generation are few of the factors spurring this steady demand. The other factors steering its growth are an increased emphasis on food security and environmental concerns.

2 » HPS vs. LEDs

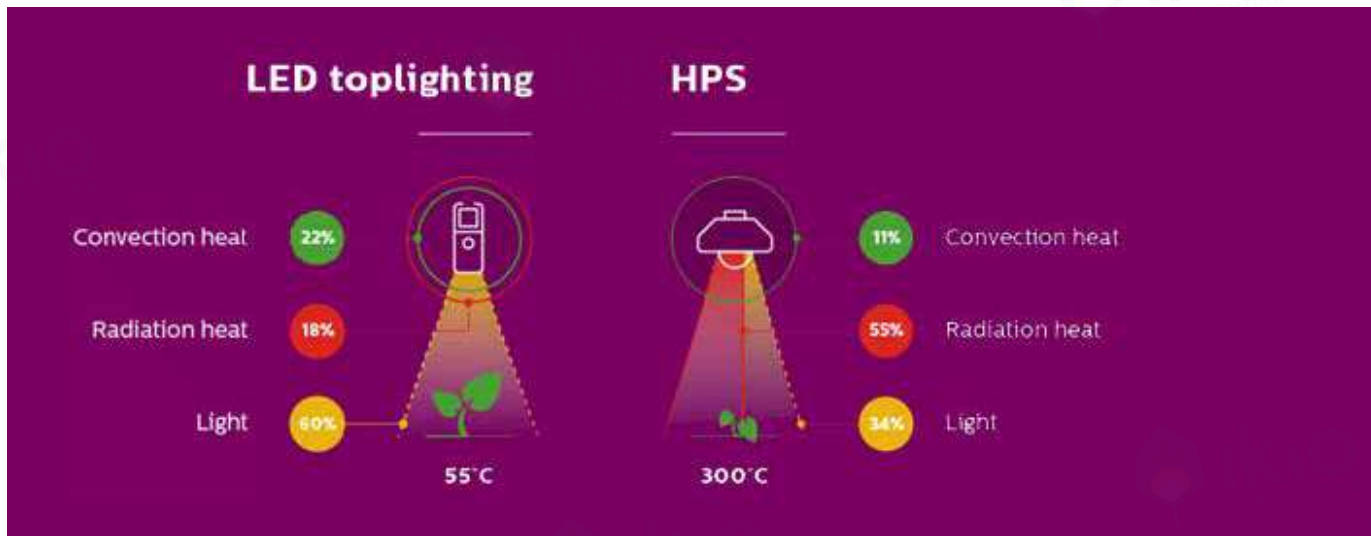
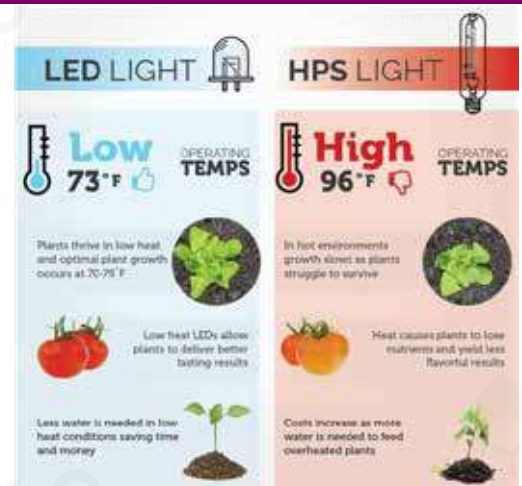

Figure 88. A comparison of heat and light from an LED-based and HPS based grow light

A horticulture grower is always looking for ways to optimize growth results, minimize risks and increase yield.

This can be realized through predictable, high-quality, high production crops or plants delivered all year round. A successful LED-based growth strategy helps in achieving all of them.

Figure 89. Infographic showing the pros of LED based growlights over their HPS counterparts



3 » Benefits of OF LEDs

Better Yields:

HPS-based lamps have been previously said to result in bigger yields, but nowadays every reputable commercial cannabis grower has started using LEDs.

To make a simple comparison – a 600-watt HPS light yields up to 300 grams for the space its light covers, which translates into half a gram for each watt. In comparison, an LED grow light yields up to 1.5 grams per watt while using a lot less electricity to produce the same luminosity.

Longer Lifespan:

A regular HID light has a lifespan of close to 10,000 hours, which might seem like an impressive number but in the long run, LEDs are a better option. A good quality LED grow light can be perfectly functional from up to 50,000 to about 100,000 hours.

Heat Efficiency:

HID lights are notorious for how much heat they produce. In comparison, LEDs are very efficient in terms of heat management and can be placed

much closer to the plants. This saves the grower any additional costs for a big and sophisticated ventilation system.

Spectrum Control:

The greatest advantage of LED grow lights is the adjustable spectrum. Plants benefit from light in different spectrums during the different growth stages, so having all of that in one light is a great plus. No need to switch the bulb itself to get light in a different color as you would need to do with HIDs.

Energy Saving:

LED lights are more energy-efficient and need to be replaced a lot less often than HID lights. This results in saved money and efforts.

Additionally, HIDs start losing their brightness as time passes and need to be replaced even before they're completely done. LEDs, on the other hand, maintain a constant level of luminosity for as long as they're functional.

4 » LED Toplighting Systems

LED toplighting delivers very high light output while radiating much less heat than their HPS counterparts. They allow users to control light and temperature more separately from each other to reach unprecedented lighting levels for plants and gain more control over growing conditions. They can be used in conjunction with customized lighting recipes (according to various plant needs) to shorten growth cycles, increase yields, reduce energy and enable more economic use of space.



Figure 90. (Left) IKIO Prolife Linear growlight. (Right) LED toplighting systems being used to grow cannabis

5 » LED Interlighting Systems



Figure 91. LED interlighting modules in use in tomato cultivation

Placing lighting within the canopy of high wire plants directs and focuses growth-stimulating light on the most vital part of the crop. With the sideways light distribution pattern, the leaves can optimally transform the light into growing more yield.

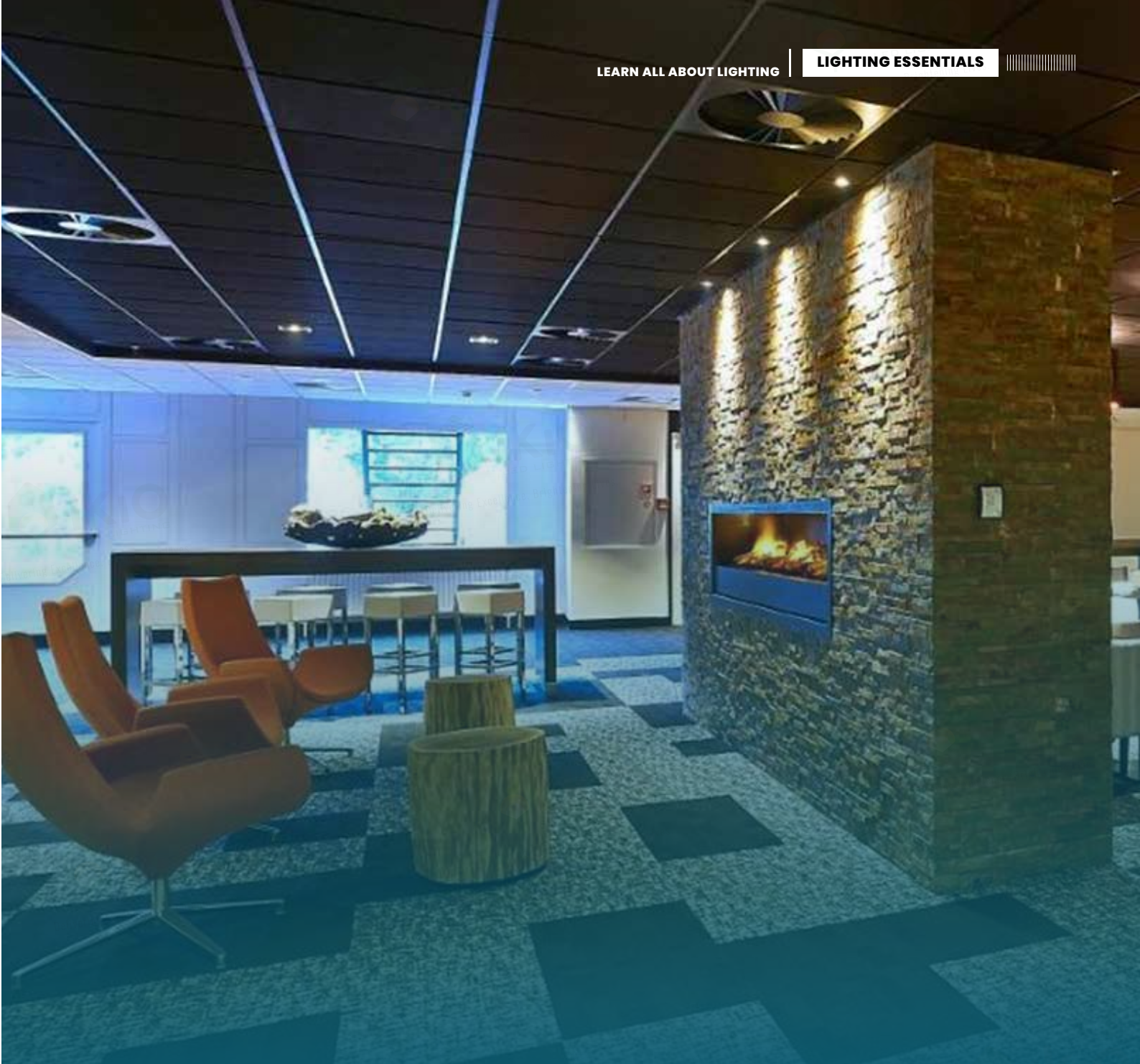

13 » MULTIFAMILY RESIDENTIAL & HOSPITALITY LED LIGHTS



1 » Downlights



Figure 92. IKIO Taz CCT Tunable downlight

LED downlights can come in various shapes, forms, and applications- Outdoor Downlights / Exterior Downlights, Recessed Downlights, etc. For users who aren't ready to spend on upgrading their existing lighting infrastructure, LED Downlight Retrofit fixtures are a good way to capitalize on the benefits of LEDs.

Applications: Interiors of offices, conference rooms, hospitals, retail, hotels, museums, and multifamily residential spaces.

Types of fixtures: Recessed retrofit panel downlight, CCT tunable downlight, retrofit J-box downlight, Driver on board (DOB) recessed retrofit downlight, etc.

LED Downlights are light fixtures that can be easily installed into a hollow space in the ceiling. They are brilliant energy-saving lighting solutions that are designed for a plethora of applications. LED Downlights emit light in a downward direction with an accurate and narrow beam.

2 » Ceiling Lights



Figure 93. IKIO Flush mount ceiling lights: (from the left) Corona, Nimbus and Quadrin

Perfect for ambient lighting in any room, ceiling lighting can be found in every home. Ceiling lighting is commonly used in spaces like bathrooms, bedrooms, dining rooms, hallways, closets and family rooms. Perfect for ambient lighting in any room, ceiling lighting can be found in every home. Ceiling lighting is commonly used in spaces like bathrooms, bedrooms, dining rooms, hallways, closets and family rooms.



Figure 94. A hallway with flush mount lighting and sconce lighting

There are differences between types of ceiling light fixtures. There are five main kinds: flush mount, semi-flush mount, track lighting, pendant fixtures and chandeliers. We'll cover the most common one- flush mount lights.

Flush mount lighting is a type of lighting fixture that has little to no gap between the fixture itself and the ceiling. It can come in many shapes, the most common being circular, but you'll also find oval, square and rectangular flush mount light fixtures. This style of light will easily and seamlessly blend with the interior decor. Most flush mount fixtures are pretty minimal in style, but it is still possible to find ornate, decorative styles with many designers.

Applications: Kitchens, Hallways, Entryways, offices, conference rooms, hospitals, retail, hotels, museums, and other multi-family residential spaces.

3 » Vanity Lights

A vanity light, also known as a vanity bar, is a long light fixture mounted above the bathroom mirror.

The counter and mirror are the focal points of the bathroom, and vanity lighting draws attention to this important spot. Vanity lights and vanity bars come in a range of shapes, sizes, and colors.

Applications: Vanity areas



Figure 95. IKIO vanity LED lights : Vanitas 2 and Vanitas 3



4 » Under Cabinet Lights



Under-cabinet lights are a go-to choice for optimal task illumination. These unobtrusive accent fixtures seamlessly blend into kitchens without disturbing the existing decor of the room. They come in a variety of sizes and options for different switches and outlets.

Applications: Under Kitchen Counters, Cabinets and Shelving.

Figure 96. IKIO Urso under cabinet LED light

5 » Wall Sconces



Figure 97. IKIO Sconce lights: (from the left) Cylindro 1, Cylindro 3, Arko 4 and Hemis 1

Wall sconces serve two main purposes: to illuminate and to save space.

These adaptable light fixtures allow you to control lighting in small areas like corridors or foyers while keeping the area clear of portable fixtures.

Wall sconces are popular among decorators, homeowners, and contractors because they are suitable for interior and exterior spaces and look wonderful in both residential and commercial settings.

Applications: Bedrooms, living rooms, and doorways.



6 » Outdoor Ceiling Lights



Figure 98. IKIO Ardeco 1 Outdoor LED ceiling light

Outdoor ceiling lights are flush mount fixtures meant for illuminating covered outdoor spaces. Available in various styles and finishes, these lights spruce up building outdoors gracefully. Being outdoor lights, they are usually designed to withstand harsh outdoor conditions to some extent.

Applications: Ideal for Entrances, Hallways, Porches or other outdoor Heavy-duty applications.

7 » Bulkhead Lights

Bulkhead lights are a practical, economical way of lighting up outside spaces when functionality is just as important as style. The light is contained within a bulkhead, with simple lines and an industrial look.

Applications: Ideal for Entrances, Hallways, Porches or other Heavy-duty applications.



Figure 99. IKIO Bulkhead lights:(from the left) Valora1, Valora 2, Valora 3

8 » UP-Down Lights

Up-down lights are minimalistic contemporary fixtures that have light sources at the top and bottom ends. These are great accent lighting fixtures that can be used to add extra character to areas to augment the aesthetic quality of the space.

Applications: Entrances, Entryways, Porches, Hallways, etc.



Figure 100. (Left)Up-down lights illuminating a hallway. (Right)IKIO up-down lights: (clockwise from top left) Cinza 1, Nero 3, Slitz , and Slitz 2



9 » Lantern Lights

LED lantern lights are designed to imitate the elegant timeless look of lanterns. These lights combine the qualities of LED light sources and classical designs to add timeless aesthetics to outdoor spaces. They also come in multiple finishes and options of a photosensor to enhance power-saving in outdoor applications.

Applications: Ideal for Entrances, Entryways, Porches or other Outdoor applications.



Figure 101. IKIO Lantern lights:(from the left)Archis 1, Classica 2, Eterna 1, and Klassico 1

10 » Wall Lights



Figure 102. IKIO wall lights: (from the left)Odion 2, Rollo 2, and Rollo 3

Wall lights can instantly turn a flat wall into something decorative and worth noticing. Specifically designed to add ambient lighting in a variety of spaces, more of today's wall sconces and wall lamps are shaped to add dramatic up and downlighting effects, really adding depth and structure to a room.

Applications: Interiors of living areas and bedrooms in multifamily residences and hospitality areas.

11 » Porch Lights

Porch lights are a great way to add not only light to the entrances but also style and elegance. Porch lighting is also a necessary safety feature for a lot of houses with particularly dark garden paths. They are a quick way to add aesthetic value as entrance feature lights to make a positive impact.

Applications: Ideal for Entrances, Entryways, Porches or other outdoor applications.



Figure 103. IKIO Porch Lights: Velum 1, Velum 2 and Velum 3

12 » Outdoor Downlights



Figure 104. IKIO Outdoor Downlights: Grillis and Nora 2

Outdoor downlights or external downlights are outdoor accent lighting fixtures with downward throwing narrow light beams.

These are a great addition to contemporary styled properties as they work towards enhancing the aesthetic quality of facades.

Applications: Ideal for Entrances, Entryways, Porches or other Outdoor applications.



4 » SOLAR LED LIGHTING

1 » Introduction

Solar power and LED lighting form the perfect combination, kind of like peanut butter and jelly. They work very well with each other to complement their best attributes. The sheer nature of solar power makes it a near-perfect solution for any outdoor lighting application from parking lots to street lights.

Outdoor lighting is typically only needed during the night, which leaves the daytime for obtaining solar energy that can then be converted to electrical power and used in powering light sources at night.

The benefits of solar power could be negated if implemented with inefficient lighting technologies. That's what makes the combination of solar power and LED lighting one that has been gaining so much attention.

Figure 105. The Components of a typical integrated solar streetlight.



2 » Key Benefits

Runs on DC Power:

The traditional combo of solar panels and CFLs or halogen lights requires a converter to run the lights. This causes a major loss in power and requires the solar panels to be larger and the batteries to have extra storage.

But, that is not the case for LED lights powered by solar panels. LEDs run directly from DC power and doesn't require a converter or extra power to make up for the loss in their efficiency. Most importantly, LEDs provide a better quality of light and have the best lumen per watt ratio.

Better Light Quality:

LEDs win by a large margin against the traditional light sources when it comes to light quality. The technologically advanced LED lights can produce light colors present in any part of the lighting spectrum. From cool blue-white like CFLs to warmer yellowish glow like that of incandescents, LED lights come in a variety of colors, making them suitable for all sorts of applications. LEDs again take the top spot when it comes to Color Rendering Index (CRI). With 80+ CRIs, LEDs ensure that they make everything look stunning when used in street, landscape, decorative and mood lighting.

Better Visibility

The bright white of LEDs provides a better CRI

(color rendition index) and less flicker, which provides better sight at night. This is better for security and puts less strain on the eyes. Less strain means that people who have to work or drive at night will be less tired.

More Lighting time

LED lights use a fraction of the power needed for one incandescent lamp and one third less power than compact fluorescent lamps. They provide better efficiency and light quality for the same size of the solar panels used for their traditional counterparts, which make their combination extremely effective and allows for higher lighting durations.

More Sustainable

Solar power provides power for applications without using any other source of energy other than the sun, and LEDs use that energy to provide lighting. LEDs also use no mercury or other hazardous materials, making them safe to recycle when they eventually go out.

Works Off the Grid

Given that solar LED lights are powered by the sun, so it goes without saying that they can work in areas that aren't connected to the grid. This expands the application of LED lighting in areas where there are no grids or setting up one is an uphill task.

3 » Solar Streetlights

As evident from the name, they are solar lights meant for lighting roadways, highways and streets. The integrated versions of these lights are more compact as all of its components are housed together. These lights are meant for mounting heights of 3-10 meters. They come with various light control features like PIR sensors, timer on-off and brightness adjustments. Some variants also come with a remote control to access these fixtures.

Applications: Airports, highways, roadways, streets, large parks, and other outdoor applications.



Figure 106. LED Streetlights:(left) Integrated and split type (right)

4 » Solar Plaza Lights



Figure 107. Solar Plaza light from a leading light manufacturer

Solar plaza lights are designed to illuminate areas from mounting heights ranging between 3 to 6 meters. Like most solar lights, they come with remote light controls and PIR and photosensors for effective light management. Available in various trendy designs, they are a great way to provide low maintenance, off the grid lighting in parks and plazas to add to the ambiance of the area.

Applications: Squares, courtyards, gardens, plots, parks, parking lots, streets, and other outdoor applications.

5 » Solar Wall Wash Lights

Solar outdoor wall wash lights are low maintenance off the grid accent lighting fixtures. They are a great way to augment the aesthetic quality of property outdoors. Their illumination accentuates the texture or shape of the surface on which they are mounted.

Applications: Garden walls, building facades, and other outdoor applications.

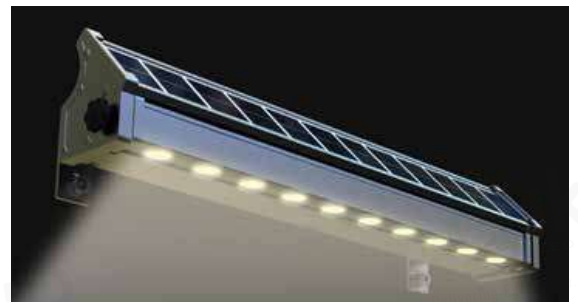

Figure 108. Solar LED wall wash fixture from a leading manufacturer

6 » Solar Wall Lights



Figure 109. Integrated solar outdoor wall lights

Solar wall lights are economic outdoor lights that do not require connection to the electric grid. They come with effective light management systems like PIR motion sensors and photosensors.

Applications: Garden walls, building facades, stairwells, entryways, perimeters, and other outdoor applications.

7 » Solar Bollard Lights

Solar bollard lights are one of a kind decorative light fixtures mostly used to illuminate pathways and driveways. They come in many attractive designs to match the landscape design theme. In addition to great aesthetic styles, these fixtures come with PIR motion sensors and photosensors to enable smart light controls.

Applications: Squares, courtyards, gardens, plots, parks, pathways and other outdoor applications.



Figure 110. Solar LED bollard lights in classical and contemporary designs

8 » Solar Landscape Lights



Figure 111. Solar LED landscape lights: (clockwise from the top left) Spherical garden light, pillar mount lantern lights, wall mount lantern light, decorative spot light and inground deck light.

As evident from their name, these lights are not just for the purposes of illumination but also to augment the landscape designs at night. Given that they work off the grid, their placements do not require complex wiring plans to connect the lights to the property's electrical circuit. It also allows a lot of leeway to their users to decorate their outdoor landscapes without worrying about hefty power bills. And just like their other solar lighting counterparts, they come equipped with PIR motion sensors and photosensors.

Applications: Pathways, gardens, swimming pool deck, garden walls, foliage lighting, façade lighting, and other outdoor applications.



15 LOW VOLTAGE LAMPS



1 » Introduction

Most Low Voltage lamps for architectural use are designed to operate at 12 volts, a much lower voltage than the 120 or 277 volts normally used for lighting circuits.

As a result, for a given wattage, the lamp filament can be much smaller for a given wattage. The key to the effectiveness of low voltage lighting is the small size of the filament in the lamp; it permits better

light control in smaller fixtures. The combined effect is very dramatic.

Aesthetically, low-voltage lighting systems might seem out of date today, but the complexity of installing such a system and the coordination of components has several affinities with today's LED lighting when it comes to the source, power, circuitry, and dimming.

2 » Types of Low Voltage Lamps

Most low voltage lamps use tungsten halogen technology, taking advantage of the compact filament, high efficacy, longer lamp life and lumen maintenance.

Low voltage lamps require a transformer to reduce the higher circuit voltage to the voltage for which the lamp is designed, which is typically 12 volts.

There are four basic families of low voltage lamps: MR, PAR, Aluminum Reflector, and Capsule.



Figure 112. Low voltage lamps: (from the left)MR, PAR, Aluminum reflector and capsule

3 » Mr Lamps



Figure 113. MR light bulb shapes

MR11 and MR16 lamps are reflectorized tungsten halogen lamps. These lamps are particularly effective for accent lighting.

MR16 lamps are the most popular of all low voltage lamps. A range of beam patterns from 7 to 55

degrees are available, and a range of wattages from 20 to 75 watts. MR lamps are available in bi-pin and TAL (twist & lock) bases. A separate cover glass is required for most MR16 lamps, but some types are available with an integral cover glass.

Most MR lamps feature a dichroic filter, producing a cool beam. Some dichroic filters produce a characteristic greenish-purple backlight, which may be distracting in an open fixture. MR technology has advanced in the last decade, offering continuing improvements in lamp life and output in a variety of models.

4 » PAR Lamps



Figure 114. Various PAR light bulb shapes

With a wide range of PAR lamps shapes, applications vary greatly, including theatrical lighting, museum lighting, track lighting and outdoor floodlighting. Not only is

there a wide difference in shape, but there is a substantial range of lumen outputs tailored to different applications.

Low voltage PAR36 lamps include the popular PAR36 and higher wattage PAR56 and 64. Low voltage PAR lamps are of sealed beam pressed glass construction. The aluminized glass reflector concentrates the beam, a glare cap blocks stray light from the filament, and the glass lens determines the beam pattern; from a very narrow spot to a very wide flood.

5 » Aluminum Reflector Lamps

Aluminum Reflector lamps are reflectorized tungsten halogen lamps of metal construction. The two most popular aluminum reflector lamps - AR70 and AR111 - feature an anti-glare shield over the filament, producing a well-controlled beam. AR70 lamps, 20-75 watts, use a TAL base. AR111 lamps, 75-100 watts, use screw terminals. Both lamps require a glass cover.

These lamps are sized in millimeters not 1/8s of an inch. The AR70 is $\frac{3}{4}$ " larger than an MR16; the AR111 is about the same size as a PAR36. None of the lamps are interchangeable.



Figure 115. Different AR lamp shapes

6 » Capsule Lamps

Capsule lamps are a non-reflectorized low voltage light source. Most capsule lamps are tungsten halogen, such as the T4, with power up to 75 watts. They require protective cover glass.

These lamps are commonly used in landscape or small-scale linear or under-cabinet lighting systems.

7 » Color

Halogen lamps are especially effective in lighting crystal, jewelry and food displays, whereas ordinary low voltage lamps have a color better suited to mixing with line voltage incandescent, in restaurants and living areas.

Color filters are available for most low voltage fixtures and permit a wide range of visual effects. With a few exceptions, the PAR36 low voltage lamps are ordinary filament lamps. These lamps have a somewhat warmer color, about 2800K.

8 » Transformers

Low voltage lamps are generally operated in fixtures which that contain a transformer. The transformer reduces line voltage (usually 120 volts) to the lower voltage required by the lamp (most often 12 volts). Transformers are either magnetic or electronic. The benefits of magnetic transformers are dependability, lower cost and compatibility with

ordinary inductive load dimmers. Electronic transformers are small in size, lightweight and offer higher efficiency.

Transformers may be integral, mounted within the fixture, or remote, serving several fixtures wired together.



9 » Voltage & Lamp Life

Effective lamp life depends on the actual voltage that reaches the lamp.

The output voltage varies with the wattage of the lamp used; the higher the wattage, the lower the actual voltage output by the transformer. If the voltage to the lamp is higher than rated, the lamp life will be reduced.

Therefore, transformers are built to optimize the operation of certain ranges of wattages: either 20W-50W or 42W-75W. Each transformer is “tuned”

so that the lowest wattage lamp sees rated voltage and the highest sees a slightly reduced voltage, which extends lamp life.

Using a lamp below the recommended range will result in short lamp life. The PAR36 “pin-spot” (25 watt, PAR36) lamp is rated 5.5 volts (rather than 12 volts); therefore, the luminaire utilizing this lamp needs to be equipped with a transformer capable of producing 5.5 volts.

10 » Dimming

Dimming can enhance the effect of low voltage lighting, especially where a special atmosphere or multiple settings are desired. As with other incandescent lamps, dimming warms the color of the light and extends lamp life.

The dimming of low voltage fixtures is best carried out with magnetic transformers and dimmers that are rated for magnetic low voltage or inductive loads.

11 » Noise

There is some noise produced by low voltage lamps. Noise can also be produced by transformers, especially when dimmed. This noise can be audible in some situations, depending

on the lamp/transformer combination. A high inductance filter will significantly reduce this noise.



16 LED POWER SUPPLY



1 » Introduction



Figure 116. A constant current MEANWELL driver (left). A 50W 12V 4.16A Constant Voltage Triac Dimming LED Driver (right)

LED's work most efficiently and safest with a "constant-current" drive. As a result, many new devices have been developed to provide this type of LED drive. LED power sources that provide a "constant-current" output have typically been referred to as LED drivers. In the past, AC-DC power supplies that provided a regulated "constant-voltage" to LEDs were referred to as LED power supplies. Today, the terms "LED driver" and "LED power supply" are used interchangeably.

2 » Constant Current Supply

In cases where a manufactured cluster or string of LEDs does not include an internal "constant-current" driver, an external LED driver or power supply that provides a "constant-current" is required. Constant-current LED drivers are available in many different package configurations, ranging from integrated circuits to enclosed moisture-proof packages, depending on the application and the required output power.

Advantages of a constant current LED driver:

When working with high powered LEDs, it is best to use constant current drivers because:

1. They avoid violating the maximum current specified for the LEDs, therefore avoiding burnout/thermal runaway.
2. They are easier for designers to control applications, and help create light with more consistent brightness.

3 » Constant Voltage Supply

Most commercially available LED "light modules" are constructed by connecting a number of LEDs in series or parallel to form clusters or string configurations. In cases where these light modules include a "constant-current" driver as part of the assembly, an external "constant-voltage" driver or power supply is required.

Advantages of a constant current LED driver:

1. Constant voltage is a much more familiar technology for the design and installation engineers.
2. The cost of these systems can be lower, especially in larger-scale applications.

4 » UL Class 1 Driver



UL Class 1 drivers have output ranges outside UL Class 2 designations.

An LED Driver with a UL Class 1 rating has a high-voltage output and safety protection is required within the fixture.

A Class 1 driver can accommodate more LEDs, making it more efficient than a Class 2 driver

UL Class 2 Driver

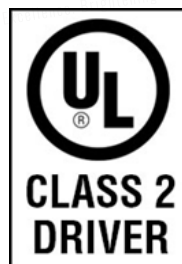

UL Class 2 drivers comply with standard UL1310, meaning output is considered safe to contact and no major safety protection is required at the LED/luminaire level. There is no risk of fire or electric shock.

These drivers operate using less than 60 volts in dry applications, 30 volts in wet applications, less than 5 amps, and less than 100 watts. However, these limitations pose restrictions on the number of LED's a Class 2 driver can operate.

5 » IP Rating

P ratings tell users the environmental protection that a driver's outer casing provides. The first number specifies protection against solid objects, and the second number specifies protection against water elements.

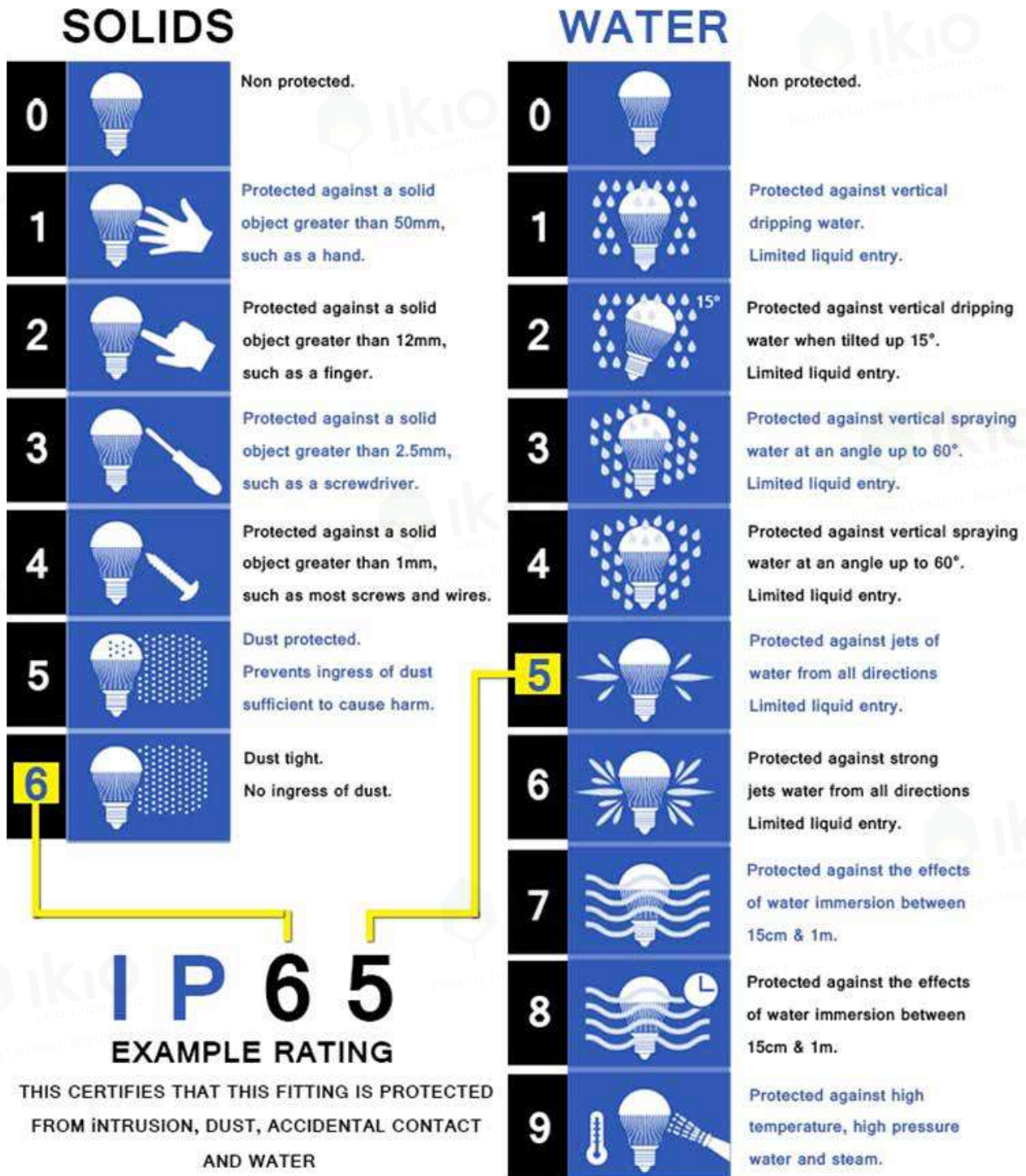

Figure 117. The IP rating chart



17

» CERTIFICATIONS

1 » DLC



Figure 118. The DLC QPL and DLC QPL Premium logos. It is important to know that these logos are always used in conjunction with product codes that are listed in DLC.

The DesignLights Consortium (DLC) is a non-profit organization whose mission is to drive efficient lighting by defining quality, facilitating thought leadership, and delivering tools and resources to the lighting market through open dialogue and collaboration. They qualify commercial LED luminaires, retrofit kits, linear replacement lamps, mogul (E39/E40) screw-base replacements for HID lamps, and four pin-base

replacement lamps for CFLs on the DLC qualified product list (QPL).

The DLC's Solid-State Lighting QPL is the country's largest verified list of high performing LED lighting products. Browse Solid-State Lighting resources related to the QPL, submitting LED products for qualification, and how the DLC develops specifications and technical requirements below.

DLC Premium is a higher-performance classification for luminaires and retrofit kits. Products submitted to the DLC Premium classification must meet higher efficacy and lumen maintenance requirements and must also provide a driver ISTMT and information about integral controls.

2 » UL Certification

	Mark for U.S.	Mark for Canada	Mark for U.S./Canada
Listing mark			
Recognition mark			

Figure 119. UL Listed and UL Recognized logos for the US and Canada

Underwriters Laboratories (UL) is an American safety and consulting company offering services in 104 countries worldwide. UL "drafted safety standards for electrical devices and components as the rise of residential electricity transmission made electronics ubiquitous in American households". If a product is "UL Listed", it means that UL has tested representative samples of the product and determined it meets UL's requirements based on its published Standards for Safety.

UL Recognition certifies that a component within

a larger mechanism meets UL standards. UL Recognition is most often seen in factories, in the form of power supplies or circuit boards that are used to power other machinery. UL Recognition ensures the safety and efficiency of machinery used by workers. It also empowers companies to strive for more sustainable practices.

Because UL Recognized focuses on components, UL ensures that the equipment is properly housed. This may require additional installation precautions to protect the product from chemicals or liquids in the manufacturing process.

UL Recognized stamps are generally easier to attain than UL Listed. This is because manufacturers can pick and choose which components are certified within a larger system. UL recognition is also not as rigid in its industry standards and is, therefore, easier for a business to attain as a result.

3 » Energy Star®



Residential LED products with the ENERGY STAR® label are eligible for rebates. The US EPA (Environmental Protection Agency) introduced this program to promote the use of environmentally friendly products.

Products that earn the ENERGY STAR label meet strict energy-efficiency specifications set by the US EPA helping you save energy and money while protecting the environment.

To earn the label, ENERGY STAR® products must be third-party certified based on testing in EPA-recognized laboratories. In addition to up-front testing, a percentage of all ENERGY STAR® products are subject to "off-the-shelf" verification testing each year.

To qualify for ENERGY STAR® certification, LED lighting products must pass a variety of tests to prove that the products will display the following characteristics:

1. Brightness is equal to or greater than existing lighting technologies (incandescent or fluorescent) and light is well distributed over the area lighted by the fixture.
2. Light output remains constant over time, only decreasing towards the end of the rated lifetime (at least 35,000 hours or 12 years based on use of 8 hours per day).
3. Excellent color quality. The shade of white light appears clear and consistent over time.
4. Efficiency is as good as or better than fluorescent lighting. • Light comes on instantly when turned on.
5. No flicker when dimmed.
6. The fixture does not use power when it is turned off, except for external controls, whose power should not exceed 0.5 watts in the off state.

4 » Certified Subcomponent Database (CSD)

The Certified Subcomponent Database (CSD) supports the qualification of ENERGY STAR® Luminaires by providing certified performance data for lighting subcomponents.

The use of the CSD is optional for luminaire manufacturers. It is intended to streamline the qualification process; subcomponents are not required to be listed on the CSD to be employed in an ENERGY STAR® certified luminaire.

The CSD is designed to contain certified

performance data for lamps, ballasts, fluorescent lamp-ballast platforms, GU24 based self-ballasted compact fluorescent lamps and HID lamps, GU24 based LED lamps, and LED light engines. Subcomponents in this database are not ENERGY STAR® certified as a result of being listed. Subcomponents only certified for purposes of the CSD. GU24-based integrated lamps that are ENERGY STAR® certified may appear on both the CSD and the lamps' qualified product list.

5 » Title 24 (California)



Several jurisdictions across the US have formulated their own regulations that have to be followed by business owners inside the state limits.

Title 24 California Building Standards Code is a broad set of requirements for “energy conservation, green design, construction and maintenance, fire and life safety, and accessibility” that apply to the “structural, mechanical, electrical, and plumbing systems” in a building.

Lighting power density (LPD) is a big part of Title 24 lighting compliance in commercial applications. Defined as “the total rated wattage of lighting fixtures used in a building or space per square foot,” LPD essentially designates specific wattage allowances to specific spaces throughout a building. There are three main methods for meeting LPD requirements under Title 24: prescriptive, performance, and tailored.

The most straightforward method for compliance is by using the prescriptive method, which essentially gives baseline wattage requirements per space. The key here is the maximum rated wattage of the fixture, or luminaire, not that of the lamp, or bulb. As a result, the easiest way of meeting Title 24 LPD standards is to use an LED retrofit kit that reduces the maximum rated wattage of the original fixture or an integral LED fixture in your application.

6 » ATEX & IECEx



ATEX is derived from the term 'ATmosphere EXplosibles' and it is a mandatory certification for all products to be sold across Europe. ATEX consists of two European Directives that mandate the type of equipment and work conditions allowed in a hazardous environment.

ATEX 95 Directive. The ATEX 2014/34/EC Directive, also known as ATEX 95, applies to the manufacture of all equipment and products that are used in potentially explosive environments.

ATEX 137 Directive. The ATEX 99/92/EC Directive, also known as ATEX 137, is aimed at protecting the health and safety of employees who are constantly exposed to potentially explosive working environments.



IECEx stands for the certification by the International Electrotechnical Commission for Explosive

Atmospheres. To be IECEx certified, all products must go through a monitored process by the International Electrotechnical Commission to ensure that they meet the minimum safety requirements. This process will determine if the products can be used in hazardous or potentially explosive locations.

Being IECEx certified allows the products and equipment to be traded across countries without having to be re-tested and re-certified for every country.

Key Differences between ATEX and IECEx

ATEX and IECEx is that ATEX certification only applies to countries in the EU while IECEx certification is accepted globally.

The IECEx certification is more widely recognized and accepted compared to ATEX certification.

ATEX is law-driven while IECEx is standard-driven.

7 » NSF Certification



facilities that manufacture and distribute consumer food, water, and health products. For a light fixture to be NSF certified, it needs to meet the requirements of NSF/ANSI 2.

NSF International (formerly the National Sanitation Foundation) is an independent non-profit public health and safety organization responsible for setting stringent standards for developing public health regulations, certifying equipment and products. Its main goal is to maintain the highest safety standards for all

8 » RoHS Compliance



RoHS, or Restriction of Hazardous Substances Directive, was put in place to restrict the use of hazardous materials in electrical equipment and reduce pollution in landfills.

The directive went into effect in 2006 and is heavily enforced throughout the European Union. Because of this, products sold in Canada and the EU must have a RoHS label. GLLS operates in both the United States and Canada. Products go through rigorous screening before being certified as RoHS compliant.

According to their website, "Consumers who see the RoHS marking can be confident that their LED lights don't contain unacceptable levels of mercury, lead, cadmium, hexavalent chromium, polybrominated biphenyls, and polybrominated diphenyl ethers).

» DARK SKY Certificate



The International Dark-Sky Association (IDA) is “engaged in research and development work on the issues of light pollution and how to restore the natural night environment”.

IDA’s Fixture Seal of Approval program certifies outdoor lighting fixtures as being Dark Sky Friendly, meaning that they minimize glare while reducing light trespass and skyglow. All products approved in the program are required to be fully shielded and to minimize the amount of blue light in the nighttime environment.

10 » Lighting Facts

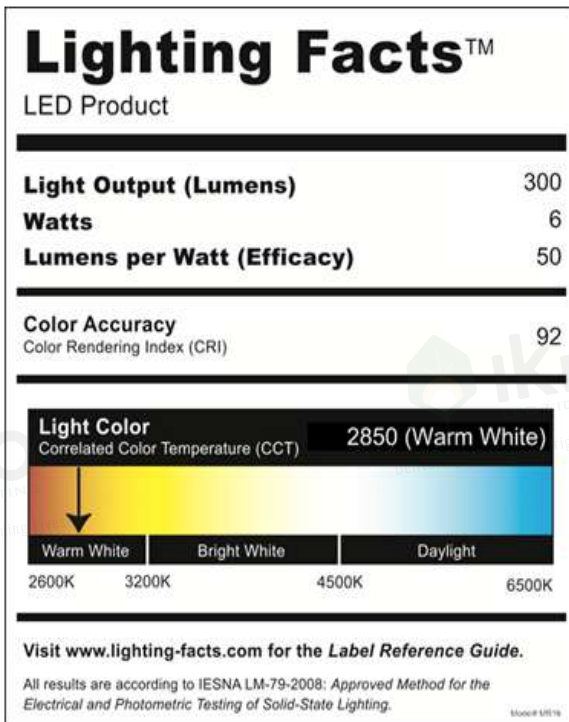

Figure 120. A DOE Lighting Facts label for an LED lighting product

The high performance and longevity of CFLs and LED lights encourage many business owners to install these lighting devices within their businesses.

The Lighting Facts certification makes it mandatory that manufacturers display the lumens value on the packaging instead of watts.

According to energy.gov, “the DOE LED Lighting Facts® program has played a pivotal role in the early adoption of SSL technology and products. After nearly a decade, the program has achieved its original objectives with significant success and is scheduled to end.

The voluntary LED Lighting Facts program was created in 2009 to help manufacturers, utilities, and others in the early days of LED lighting when products entered the market with little or no verified information on product performance. At that time, DOE technical support had assisted in the development of industry-standard test procedures such as IES-LM-79-08 and IES-LM-80-08, which enabled product performance to be reported fairly and comparably.”



18 » **INDUSTRY STANDARD TESTS**

1 » L70

L70 is a way to measure LED lifetime and is one of the most important rating electricians, purchasing agents, and end-users can use to decide which lighting fixture best suits their project. According to the United States Department of Energy,

useful life (or rated life) is “often described by the number of operating hours until the LED luminaire is emitting 70 percent of its initial light output.” It is through this definition that we find the L70 rating.

2 » LM-79-08



Figure 121. Labsphere’s TOCS system to measure IESNA LM-79 and LM-80 recommendations for LED characterization.

It is the Illuminating Engineering Society of North America (IESNA) approved method for the Electrical and Photometric Measurements of Solid-State Lighting.

It measures an LED luminaire or integral lamp as a whole system according to a standard process using specified equipment.

The testing report issued according to a standard format will provide: Total Luminous Flux, Luminous Intensity Distribution, Electrical Power Characteristics (wattage), Luminous Efficacy (calculated), Color Characteristics (CRI, CCT...)

3 » LM-79-08

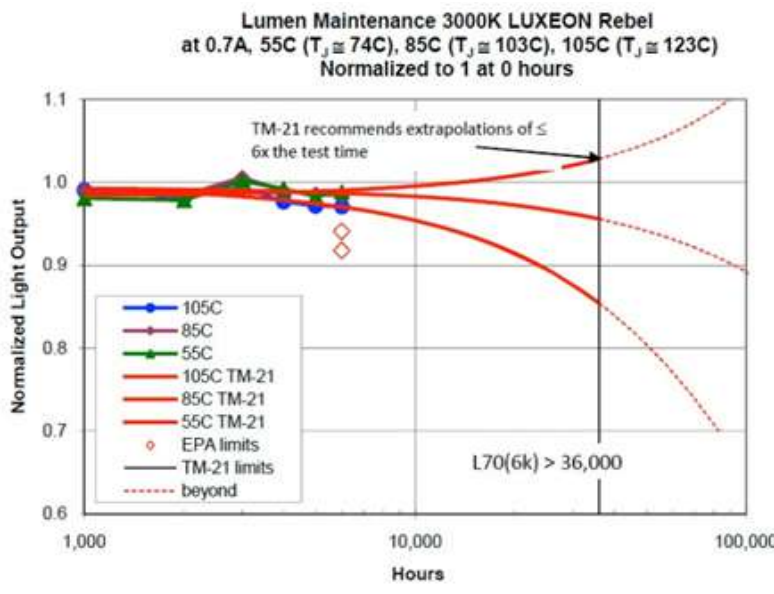

Figure 122. LM80 degradation curve of an LED light source

The LM80 test is a Department of Energy (DOE) approved method for measuring lumen depreciation of solid-state (LED) light sources, arrays, and modules.

The Illumination Engineering Society (IES) and DOE Solid-State Lighting Standards Development group worked together to create the LM80 test criteria.

LM80 is not much use on its own and does not of itself define how to extrapolate lab-measured LED lifetime test data to enable future lifetime prediction. That’s where TM21 comes in.

4 » TM-21

TM21 or TM-21-11 is the IES-recommended method for projecting the lumen degradation of an LED package, array, or module, based on data collected according to LM80. The lighting community expects TM21 to become the standard method for projecting useful LED lighting product life at realistic operating temperatures.

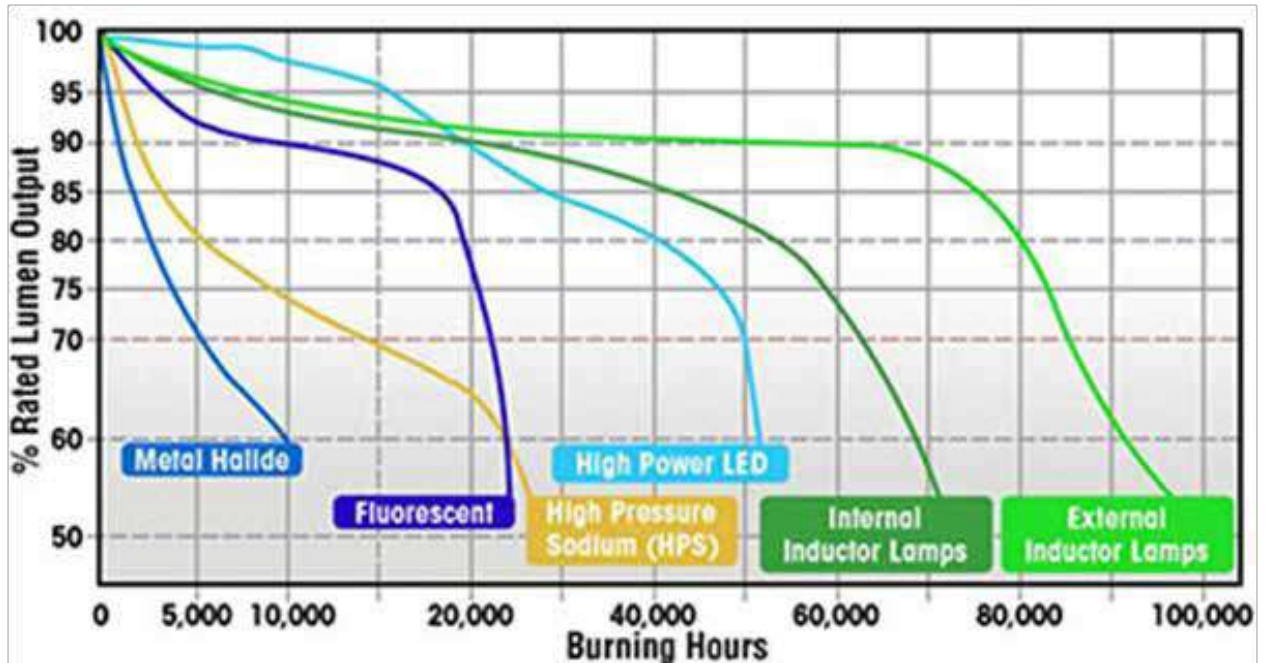

Figure 123. Lumens Maintenance curves for various commercial light types

5 » TM-28

TM-28-14 recommends the methods for projecting long-term luminous flux maintenance of LED lamps and luminaires using data obtained when testing them per IES LM-84-14. It is the approved method for measuring

lumen and color maintenance of LED lamps, light engines, and luminaires, as well as data when testing LED sources per IES LM-80-08. It is also the approved method for measuring lumen and color maintenance of LED light sources.

6 » TM-30

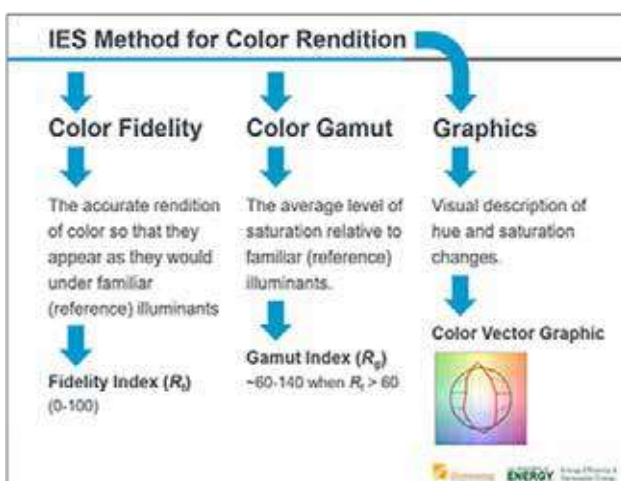

TM30 is a new quality metric that was recently adopted by the IES to supplement, and eventually replace the old CRI (CIE) Metric for measuring fidelity of a light source.

TM30 has 3 main components:

- R_f which is a similar metric to the CRI(R_a) standard that measures color rendering based on comparison to a color palette of 99 colors (CRI only had 9)
- R_g which measures the average gamut shift (hue/saturation) of the source
- A graphical representation of R_g to visually represent which colors are washed out or more vivid due to the light source.

7 » L-82

The IESNA has published LM-82-12, the approved method for determining photometric properties as a function of temperature for LED light engines and integral lamps.

The new standard references LM-79 for all photometric and electrical measurements, but

with the measurements performed at elevated temperatures. Therefore, LM-82 can be viewed as essentially the LM-79 standard procedures, but with that characterization extended to include any performance degradation of LED light engines and integral lamps that might occur at elevated temperatures.

8 » L-84

LM-84-14 provides the method for measurement of luminous flux and color maintenance of LED lamps, integrated and non-integrated; LED light engines, and LED luminaires. Like LM-80, LM-84 measures lumen maintenance at the LED lamp, light engine or luminaire level.

The method describes the procedures to be followed and the precautions to be observed in obtaining and reproducing luminous flux and color maintenance measurements under standard operating conditions.

9 » In Situ Temperature Measurement Test (ISTMT)

ISTMT is the measure of the designated critical temperature measurement points on the light source or power supply while the product is in operation. The measurement has to be performed according to the temperature measurement point (TMP) indicated by the light source or component manufacturer.

Once ISTMT is known, we check if the temperature within the luminaire is within the temperature of the LM-80-08 LED source report. It is then the basis for lifetime interpolation either based on TM-21-11 or other methods.

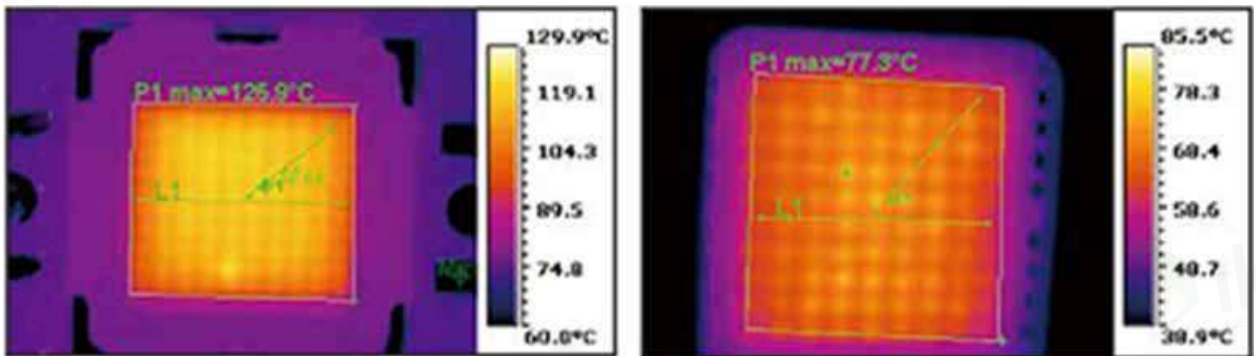

Figure 124. Thermal profile of LED light sources from two different manufacturers.



19



LUMINAIRE SYSTEM PERFORMANCE

1 » What is a Luminaire?

A luminaire is a complete lighting system. It consists of:

- a housing
- lamp holder/s or integrated LEDs
- lamp/s (if not integrated LEDs)
- the optical system
- the reflector, and either a lens, louver, diffuser or optics for controlling brightness
- it may also include some type of electrical control... dimmers, iLO (integrated lights out) switching, daylight sensors, etc.

2 » Luminaire Classifications

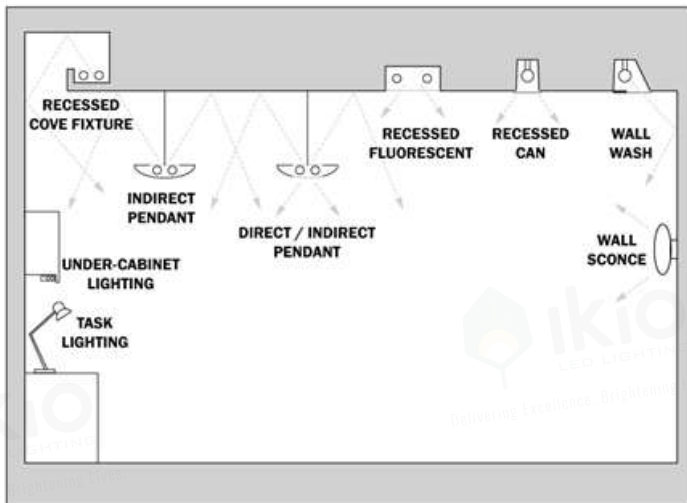

Figure 125. The various light fixture types in a habitable room

There are six basic classifications of luminaires:

1. The direct luminaire where all the light is directed down.
2. The semi-direct luminaire where the majority of the light is directed down.
3. The general diffuse luminaire where light is distributed in all directions.
4. The direct-indirect luminaire where light is distributed equally up and down.
5. The semi-indirect luminaire where the majority of light is directed up.
6. The indirect luminaire where all the light is directed up.

3 » Measuring Luminaire Performance

$$\text{LER} = \frac{\text{Photometric Efficiency} \times \text{Total Lamp Lumens} \times \text{Ballast Factor}}{\text{Luminaire Input Watts}}$$

The Energy Policy Act of 1992 (EPACT) established a requirement for a voluntary rating and labeling program for luminaires. The focus of the program is to disseminate energy efficiency information and provide a consistent metric to evaluate and compare luminaires. This metric is called the Luminaires Efficacy Rating (LER).

Luminaires Efficacy Rating (LER): The LER value expresses the total lumen output from the luminaire compared to the watts required to operate it. The LER is calculated as shown to the left.

4 » Measuring Luminaire Performance

The Coefficient of Utilization (CU) is the ratio of lumens from a luminaire incident upon a work plane relative to the lumens emitted by the lamps within the luminaire.





Light Source	Light - Source Efficacy	Coefficient of Utilization	Fixture Efficacy
CFL	 65 lm/W	 54%	35 lm/W
Xlamp XR-E Neutral White	 58 lm/W	 77%	44 lm/W

Figure 126. Comparison of CFL & LED Coefficient of Utilization

5 » Visual Comfort Probability (VCP)

The **Visual Comfort Probability (VCP)** represents the percentage of people seated in a room in a specific location and in a specific direction who would find a luminaire acceptable as far as discomfort glare is concerned.



20» LIGHTING CONTROLS



1 » Timers & Time Scheduling



Figure 127. The most commonly used timers and time scheduling controls

Timers and Time Scheduling

- Remotely installed at wall box or control area
- Lights are turned on and off at user-prescribed times or intervals

Multi-Level Switching

- Encouraged by many building codes
- Can be done at fixture level or lamp level – lights are manually or automatically switched to half on or full-on mode

Manual Dimming

- Several different technologies are common
- Most were designed to control incandescent or fluorescent lighting loads
- LED lamps and fixtures may present challenges for some of these technologies

2 » Daylight Harvesting

Daylight Harvesting is the industry term for adaptive lighting technologies that take advantage of daylight hours to offset the amount of electricity needed to effectively light a given space.

Light sensors and switching/dimming controls are matched together and programmed to take advantage of existing sunlight. Lighting fixtures are switched on/off or dimmed based on the amount of ambient light in the room.

Harvesting systems allow lighting levels to be varied based on activity levels or the time of day, and there's currently a strong push by exterior lighting decision-makers to make better use of these cost-saving technologies.

Municipalities stand to gain much in the way of reduced energy costs and light pollution by simply dimming exterior lighting during those periods when traffic use is low, and many jurisdictions are choosing to adopt such recommended measures for their exterior lighting codes and standards.



Figure 128. The photosensor (magnified) atop the IKIO Amparo Area Luminaire

3 » Occupancy Sensors

An occupancy sensor is a motion-detecting device used to detect the presence of a person to automatically control lights.

The sensors use infrared, ultrasonic, microwave, or other technology. The term encompasses devices as different as PIR sensors, hotel room keycard locks, and smart meters. Occupancy sensors are typically used to save energy, provide automatic control, and comply with building codes. Sensors can be ceiling-mounted, wall-mounted, or mounted directly to the lighting fixture.

PIR sensors are the most commonly used sensors that are mounted on the fixtures. They work on heat difference detection, measuring infrared radiation. Inside the device is a pyroelectric sensor which can detect the sudden presence of objects (such as humans) who radiate a temperature different from the temperature of the background, such as the room temperature of a wall.



Figure 129. The PIR motion sensor (magnified) underneath the IKIO Amparo Area Luminaire

4 » LEDs: Dimming Capability & Performance

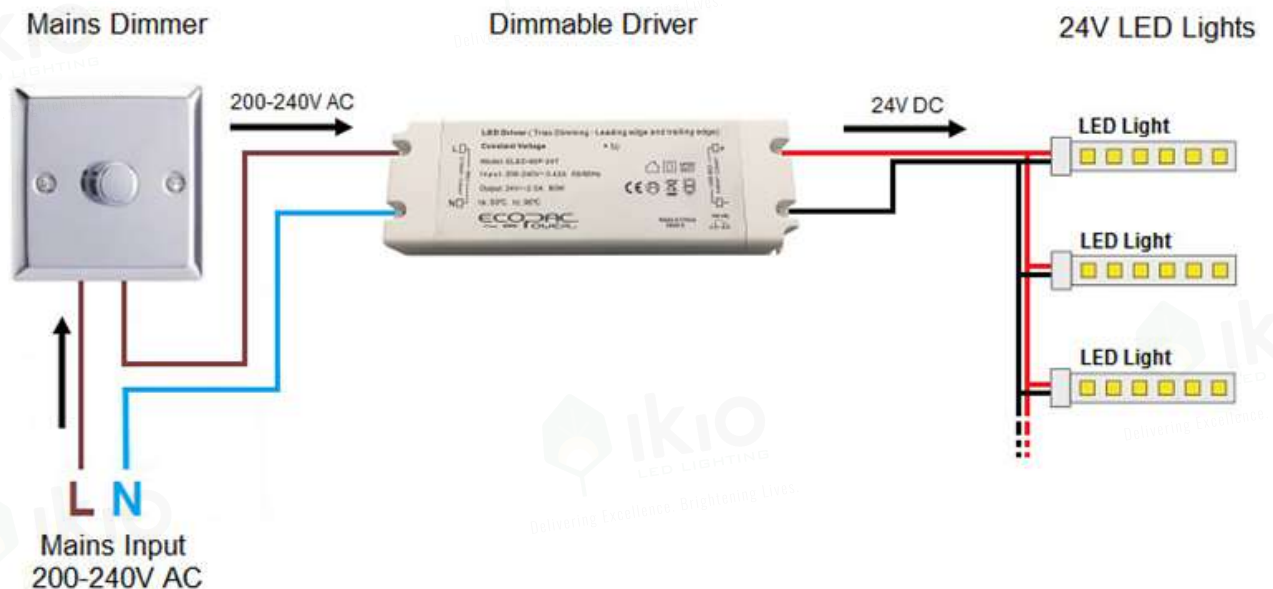

Dimming refers to a reduction in lumen output and is typically measured as a percentage of the full lumen output capability of the fixture. For example, 10% dimming refers to 10% of the fixture’s full light capability.

Dimming is an important feature of lighting control

strategies such as task tuning, time scheduling, occupancy sensing, personal control and daylight harvesting. Dimming drives the energy conservation and personalization of lighting for individuals.

Dimming has been successfully used for decades

in incandescent lamps. When LEDs first came to market, many thought the same wall dimmers that dimmed incandescent lights would work with LEDs. However, LEDs need direct current (DC)

rather than an AC power supply thus requiring a driver. Additionally, LEDs, drivers, and dimmers must all be compatible to work.

4.1. » Dimming Techniques

There are a few common methods used by commercial LED drivers to dim LEDs: constant current reduction (CCR), pulse-width modulation (PWM), amplitude modulation (AM) and a hybrid approach.

- **Constant current reduction (CCR)** dimming, also known as analog dimming, is a somewhat simple method of controlling the amount of current supplied to the LED(s). CCR dimming can have issues with dimmable LED lamps at very low current or deep dimming levels.
- **Pulse Width Modulation (PWM)** works by rapidly turning ON and OFF the LED(s). PWM works by using the exact amount of electrical current the LED requires.

Because PWM has a wide dimming range and linear relationship between light output and duty cycle, it is used more broadly. However, PWM requires sophisticated driver electronics.

- **Amplitude modulation (AM)** is a slow decrease in the drive current to attain a reduction in light output. AM is not as simple or efficient as PWM but the chance of visible flicker is evaded.
- **Hybrid approach.** A more sophisticated method of dimming is where the attributes of both PWM and Amplitude Dimming are utilized. This approach has a low risk of flicker across the dimming range. PWM is used when lower light levels are needed and amplitude dimming is used at higher levels of light output.

4.2. » Dimming Ranges

The dimming range required for an LED light is directly related to its application. For example, in an office lobby, it might not be necessary for a product to dim to 5%. However, a product that dims to only 25% would not be appropriate in a media room.

The dimming range of a fixture is based on the driver. The driver determines the achievable dimming range and the best possible performance of the lamp or fixture.

4.3. » Role of LED Drivers

The LED driver is the primary component in the fixture that determines the dimming capabilities of the fixture and significantly affects the performance, reliability, and lifetime of a luminaire. Unless it is a quality fixture leveraging a quality LED driver, the overall performance in light output and reliability could drop considerably resulting in an unpleasant experience or safety concern for the occupant.

Quality drivers can produce dimming levels as low as 1% without negatively impacting measured light output. On the other hand, low-quality LED drivers simply convert the current from AC to DC and can produce a poor quality of light resulting in flickering and stroboscopic effects.

4.4. » Common Dimming Control Methods

Several standardized control types used to dim lamps and lighting systems:

- Phase control (Triac Dimming) including forward phase and reverse phase dimming
- 0-10V dimming
- DMX 512
- ELV
- Fluorescent 3-wire
- DALI



4.5. » LED Dimming Compatibility Issues

Limited Dimming Range – lights dim down only to a percentage of full light with dimming control on the lowest level; non-compatible dimmer/driver combinations can result in only 20-30% (or less) dimming at full downward dimmer position

Flicker – perceptible light level modulation – usually occurs at the low end of the dimming range; possible safety issue

Dead-Travel – partial movement of dimming control produces little or no dimming effect

Non-Linear Dimming – a small movement of dimming control results in sudden drop or increase in light output

Drop-out – light turns completely off before full downward dimmer travel

Ghosting – light stays on with dimmer at full travel off, or with switch off

Audible Noise – buzzing or hum from fixtures under dimming conditions

5 » Considerations for Best LED Control Performance

Dimmers and daylight harvesting systems intended to control LEDs will require additional steps to ensure safety, quality and performance:

1. Make sure the types of control technologies match
2. Obtain information about the dimming range and dimming performance of the lamps or fixtures
3. Choose compatibility requirements based on application – 20% dimming may be acceptable for office spaces and lobbies, 1% may be needed for residential or hospitality applications
4. Determine the minimum and maximum load requirements for the dimmer/fixture combination



21

» THE QUANTITY & QUALITY OF LIGHT

1 » Luminaire Efficacy Ratio

Just as we can measure the luminous efficacy of a lamp (LPW), so too can we measure the efficacy of the luminaire. Electric light sources

are known in the industry as Lamps. Some lamps (such as linear fluorescent) have no reflector or other integrated means of controlling their light.

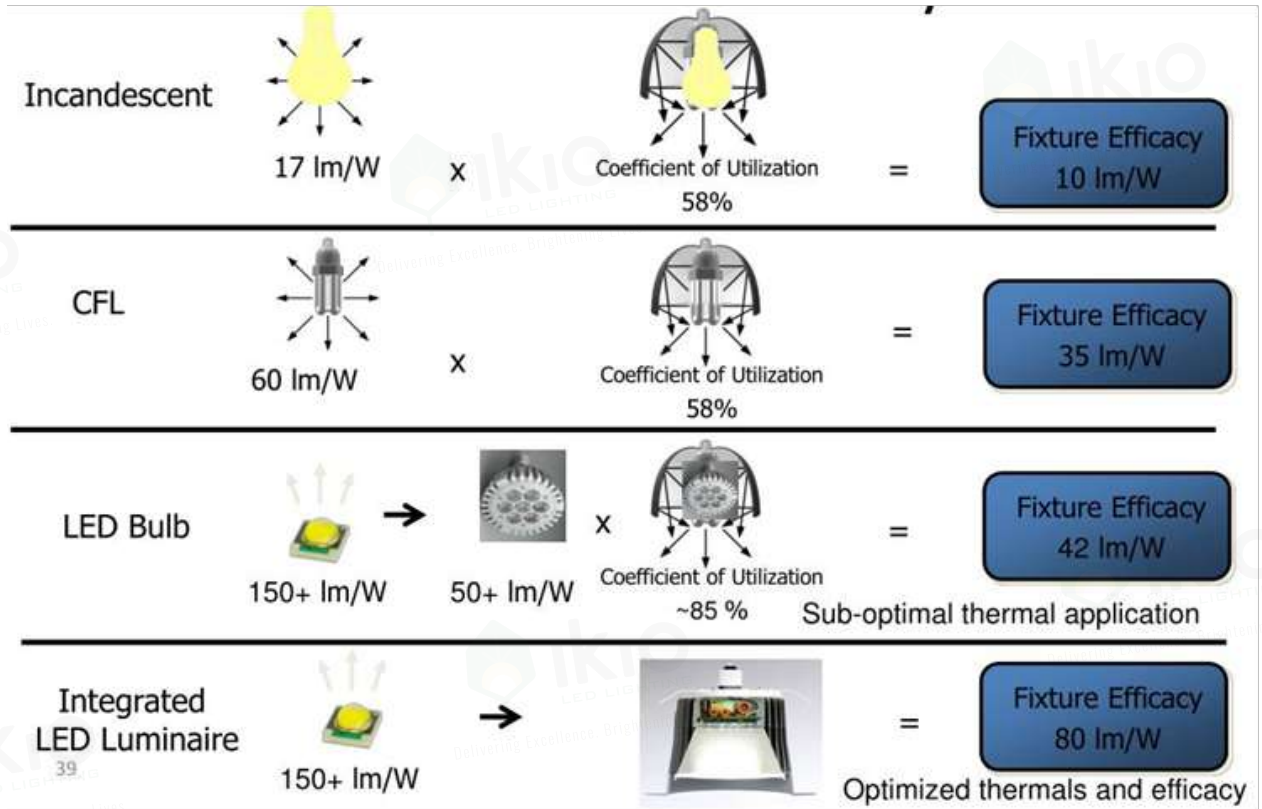

Figure 130. Contrasting lamp, fixture and luminaire efficacy

They require placement in a Luminaire (lighting fixture) having the necessary optics to deliver the lumens. However, luminaires are not 100% efficient and lumens are lost within the lighting fixture. To determine the efficacy of the luminaire a formula

was developed, which numerically expresses the total lumen output from the luminaire compared to the watts required to operate the lighting system. It is called the Luminaire Efficacy Ratio (LER).

2 » Inverse Square Law

We know from previous lessons, that the basic unit of the measurement of light is a Lumen. When these lumens arrive on a surface they are then measured in footcandles.

A Footcandle (fc) is the amount of illumination from one standard candle falling on a surface one foot away.

In the international metric system, LUX is the counterpart of footcandles. The conversion from footcandles to lux can be made by multiplying footcandles by ten. The IES recommended

illumination values are published in both footcandles and lux.

As the distance between the surface and the candle (a point source) increases, the Intensity (I) or Candelas (candlepower) reaching that surface at a given point decrease according to the Inverse Square Law.

This can be expressed accordingly; the illumination (E) equals the luminous intensity (I) of the light source divided by the distance from the light source to the surface squared.

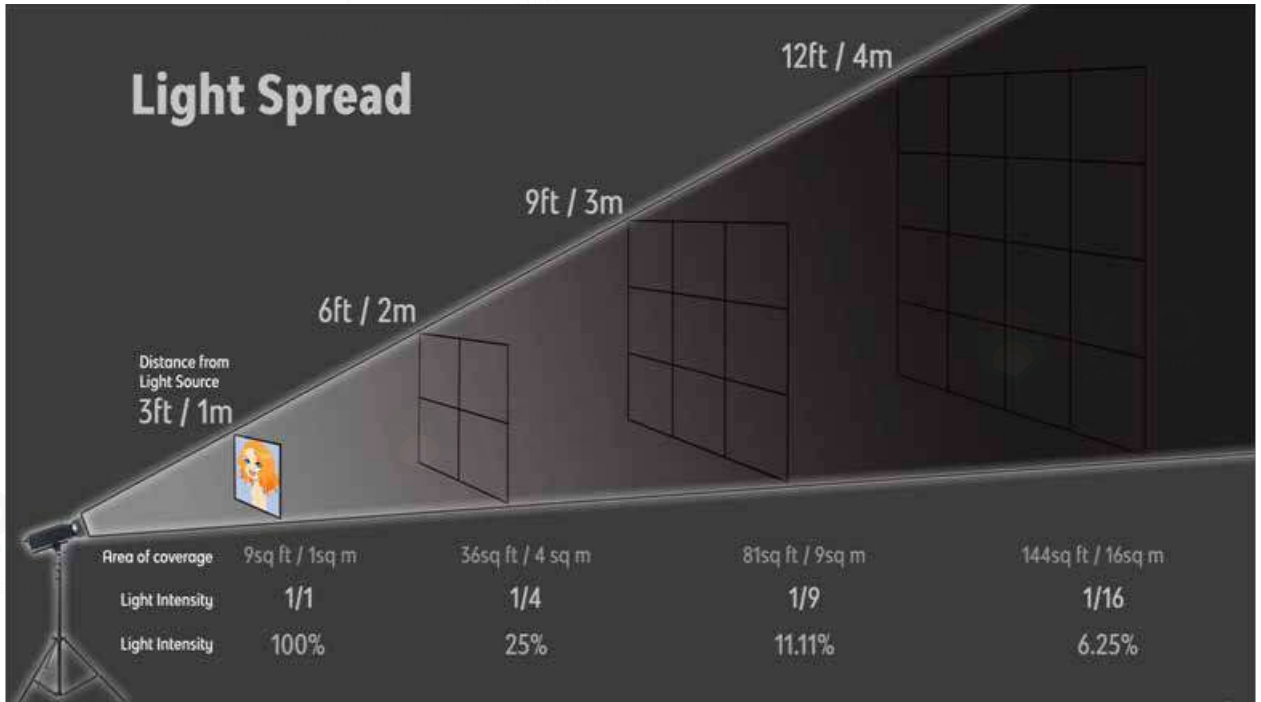

Figure 131. A visual approach to the Inverse Square Law

3 » Candlepower Distribution

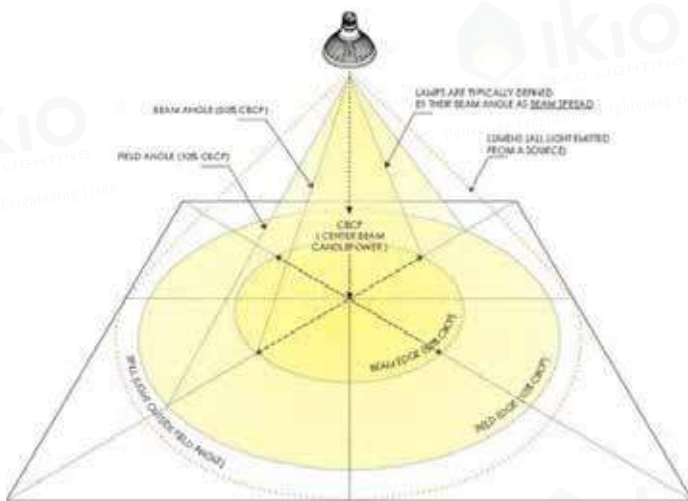

Figure 132. A fixture's CBCP visualized

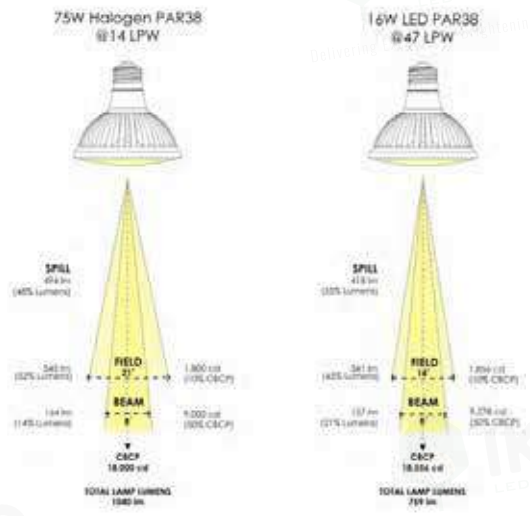

Figure 133. The CBCP of two fixtures with Halogen and LED light sources

Candlepower distribution curves show graphically the intensity of luminous flux (candelas) in a given direction. For reflector lamps such as R, BR, ER, PAR, and MR, lamp

manufacturers will show, in their publications, the Center Beam Candlepower (CBCP) for these lamp types. The beam spread for these lamps is measured to 50% of CBCP.

4 QUALITY OF LIGHT

4.1. » Glare

Glare is uncomfortable brightness in the visual field, which is annoying and uncomfortable, causing fatigue and loss of productivity.

Areas of high brightness right next to areas of low brightness cause glare, making people feel uncomfortable. For instance, having a bare light bulb for your desk lamp may provide more than enough light. However, it would cause more light to shine directly into your eyes than reflects off the desktop, making it difficult to read or do other tasks. Having a shade on the lamp keeps the light from glaring into your eyes while brightly illuminating your desktop.

Unified Glare Rating or UGR method is an international index presented by CIE (International Commission on Illumination) and is used to evaluate and limit the psychological impact of direct glare from luminaires.



Figure 134. Glare from sports lighting in a stadium



Figure 135. The various levels of UGR and their respective tolerances

4.2. » Visual Comfort Probability (VCP)

Visual Comfort Probability (VCP) evaluates the probability in a given situation that a person seated in the worst position for the glare in a room (usually at the center rear) will find the degree of glare from the lighting system just acceptable.

For example; the installation of 2 x 4 lens fixtures with a VCP of 75 would signify that 75% of the people would find it visually acceptable and 25% would not.

4.3. » Reflected Glare

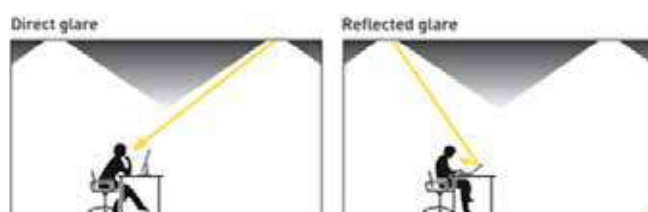

Referred glare causes discomfort and occurs when luminaire brightness is reflected from shiny (specular) surfaces in the field of view. This can include computer screens.

Figure 136. Direct glare and reflected glare visualized

4.4. » Veiling Reflections

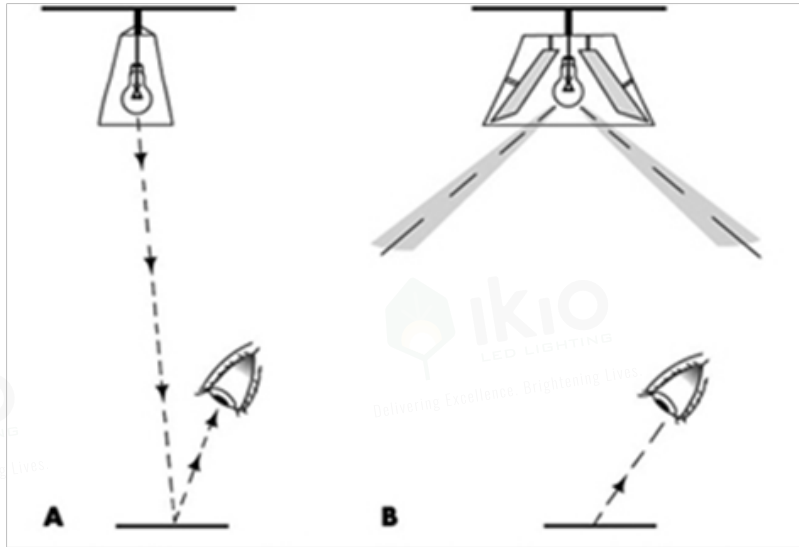

Figure 137.

- A. Veiling reflections caused by fixtures with a strong downward component of light output;
 B. Luminaires with batwing distribution to overcome veiling reflections on horizontal work surfaces.

Regular reflections superimposed upon diffuse reflections from an object that partially or obscure the details to be seen by reducing the contrast. This is sometimes called Veiling reflections are more subtle reflections of the light source in the task. They reduce the contrast between detail and background; thus, reducing visibility and obliterating detail. Some solutions for eliminating the veiling reflections are to alter the position of the viewer, alter the position of the task, or rearrange the luminaires.

22

» LIGHTING
DESIGN

The process of designing with light focuses on the following:

- **What to light.**
- **How to light it.**
- **What to light it with.**

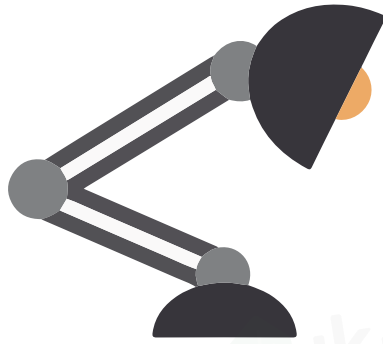

1 WHAT TO LIGHT

1.1. » Dimming Techniques



Figure 138. The various lighting approaches in a kitchen

What to light can often best be approached as a **“layered composition”**:

- Task lighting,
- Accent lighting, and
- Ambient lighting

In other words, lighting for the total environment.

1.2. » Setting Priorities



Figure 139. Setting priorities in lighting design can set the tone of ambiance in a of a space

What we see is almost always the reflection of light from a surface, not light itself. The lighting practitioner needs to consider whether the object is light or dark, polished or mirror-like, textured, or smooth. Additionally, if it's colored, is it a color to be enhanced or subdued?

The planning process follows accordingly:

- what activities (functions) will the space be used for?
- what tasks are to be accomplished in the space?
- what is the object(s) you most want to see?
- which architectural features are to be emphasized?
- where is the seating area?
- what is the desired mood (ambiance)? Does it need to be varied?
- what style must the lighting coordinate with?

Priorities need to be set. Try and give the space a focus, something which draws the eye, for instance, a table setting, a painting, a flower arrangement, a fireplace wall. Then try to consider the space as a whole, in other words, “the total lighted environment”.

- **Lighting the walls** can make a room appear more spacious.
- **Local pools of soft edge light on furniture** can create a mood of intimacy.



- **Bits of glitter and sparkle** from cut crystal or polished metal convey an air of festivity.
- **Highlighting the ceiling** with indirect lighting makes the room appear a bit more formal and spacious.
- **Highlighting a rug** on the floor with downlighting is likely to make it feel cozier; but downlighting directed onto a glossy surface, a glass table, or a marble floor is likely to cause disturbing reflections

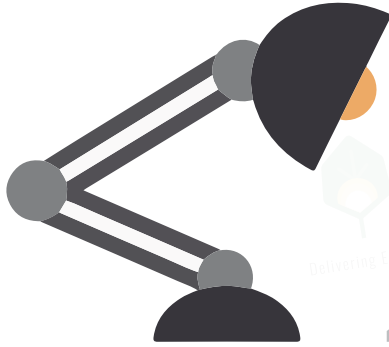

2 HOW TO LIGHT IT

Once the space has been analyzed, you can decide how best to light it using three basic techniques:

- **Ambient lighting**
- **Accent lighting**
- **Task lighting**

2.1. » Ambient Lighting - Direct and Indirect Lighting



Figure 140. (Left) Direct/Indirect Lighting Environment. (Right) Direct Lighting Environment

Ambient lighting provides general, overall illumination that enables people to move about the space easily and safely. It defines the space and makes it a comfortable visual environment. There are two approaches for ambient lighting

Direct lighting brightens objects and surfaces in the lower part of the room while **Indirect lighting** gives the feeling of spaciousness. Sometimes the two techniques are combined and work in concert to give a bright cheerful setting.

2.2. » Accent Lighting

Accent lighting focuses on selected objects and surfaces, providing drama and excitement.



Figure 141. Accent lighting focussed on paintings

3 » Task Lighting



Figure 142. Undercabinet lighting illuminates preparation areas in the kitchen and hence is a task lighting

Task lighting illuminates areas where work is performed; reading, writing, sewing, food preparation, laundry, games, and hobbies.

Writing, reading and sewing require sufficient, well-diffused, quantities of illumination that comes over the shoulder or from the side. For kitchen and hobby tasks, concentrated light from above usually works best.

4 » How Much Light

Environment	Footcandles	Lux
Living Room	10-20	108-215
Bedrooms	20-50	215-538
Kitchen-General	20-50	215-538
Kitchen-Preparing/Cooking	50-100	538-1,076
Dining Room	10-20	108-215
Rooms for Difficult Reading & Writing	50-100	538-1,076
Bathrooms	20-50	215-538
Hallways	5-10	54-108
Basement/Garage Workshop	20-75	215-807
Basement-Laundry	20-100	215-1,076
Basement-Exercise and Recreation	30	323

Figure 143. Residential recommended light levels

The quantity of light required for good vision depends on these factors:

- age
- speed
- accuracy
- the reflectance of the task

Older eyes require more light. In fact, at age 55 we need twice as much light to see as well as we did at age 20. Also, older eyes are more sensitive to glare and brightness. Thus the lighting must be both plentiful and well shielded.

5 » Determining Illuminance

The IESNA has recently revised its criteria for determining illuminance. The procedure now focuses not only on the quantity of light but, equally important, on its quality.

- Consideration is now given to the following

lighting quality issues:

- Human needs
- Economics & the environment
- Architecture

6 » Where to Place the Light

A key element in how to light is where to place the lighting.

Especially important in avoiding glare and veiling reflections. It is also a determining factor in whether a surface texture is to be emphasized or minimized.

Figure 144. The three elements of illumination in a typical kitchen space





7 » What to Light it With

Having decided what to light and how to light it, you're now ready to decide what to light it with.

The selection of the lighting system is best accomplished in the following order:

- the lamp
- the luminaire
- the controls

There is a range of light sources to assist you in making a decision. Before you make your selection, consider the following:

- Light distribution
- Electric energy consumed
- Color rendering
- Color appearance
- Maintenance costs

7.1. » Light Distribution

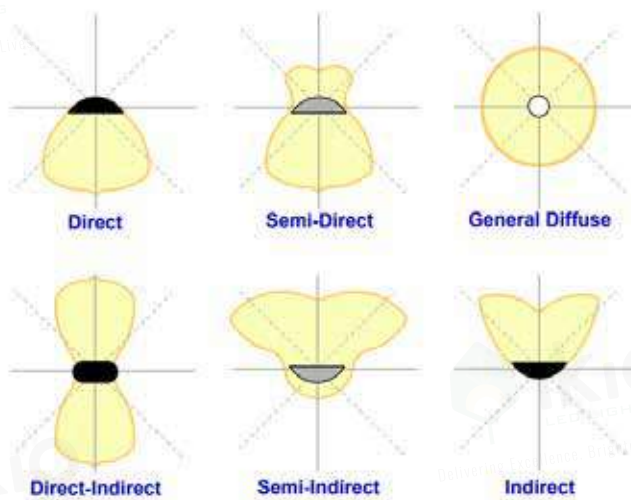

Figure 145. The various light distribution strategies

Obtaining the Desired Distribution

The desired distribution depends on the choice of both the lamp and luminaire. The lighting fixture should not only support the lamp but redirect its output into the desired zones and shield the lamp so that it does not become a source of glare.

The Purpose

Depending on whether the purpose is ambient, accent or task lighting, the required light distribution may range from broad and widely diffused to narrow and focused.

7.2. » Choosing the luminaire

The choice of lighting fixtures depends on several factors:

- Intended light distribution, function or purpose
- Appearance or style
- Mounting: recessed, surface, pendant, wall
- Type of building construction: new, existing, insulated
- Product quality: detailing, finish, durability
- Operating cost: energy, relamping, cleaning
- Initial cost

7.3. » Choosing the controls

Choose lighting controls when you want to:

- Change the lighting scene to suit the activity
- Set a mood
- Create an atmosphere
- Extend incandescent lamp life.
- Control the lights from several locations
- Save energy by turning off the lights automatically when no one is present.



23 » LIGHTING & SPACE



1 » Art and Science of Lighting



Figure 146. Lighting should provide visibility, character, and mood as well as relate harmoniously to the space in which it is used.

Lighting design is an art and a science. As a science, the amounts of illumination needed and certain aspects of the quality of light have been quantified.

As an art though, attaching numbers is meaningless because light is an experience of the senses. It is not an intellectual experience. Lighting in a space is a positive force that can motivate people to be active, relaxed, productive, lively or depressed. Lighting should make people feel important. It should create an atmosphere pleasing to the occupants whether in an office, store, restaurant or home.

2 » Effect on Architecture

Light is as much a "building material" as steel or concrete. Although such structural components are needed to enclose a space, it has no real existence until it is seen and it registers in a person's consciousness.

Light defines space; reveals texture and color; shows form; indicates scale; separates functions. Good lighting makes a building look and work the way the architect intended at all hours of day and night. It contributes to the character, to the desired attitude toward form and space, and to the effective functioning of that space.



Figure 147. Various effects of lighting on architecture

3 » Effect on Interior Design

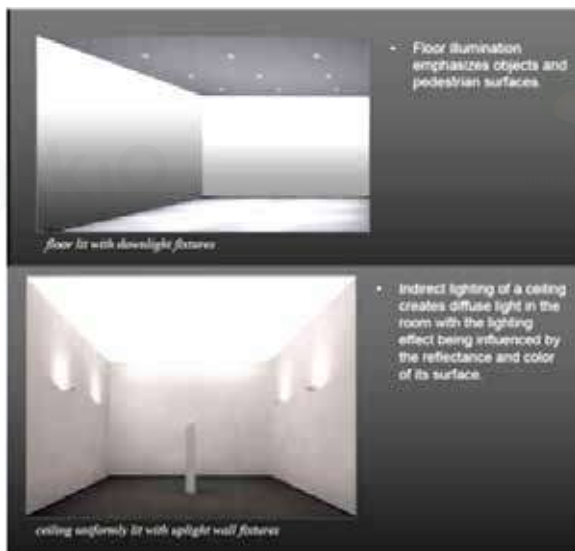

Light is invisible until it strikes a surface and molds our environment. The angle and quality of light, along with intensity, will determine how we perceive the space, its occupants and the furnishings.

The vital relationship between light and color can enhance or destroy the most carefully worked out color scheme.

Knowing the effect of light on a surface, the designer can choose the appropriate lighting system for the design requirements. The lighting practitioner needs to realize that light can make or break a space, both functionally and aesthetically.

Figure 148. Effects of light in the interiors

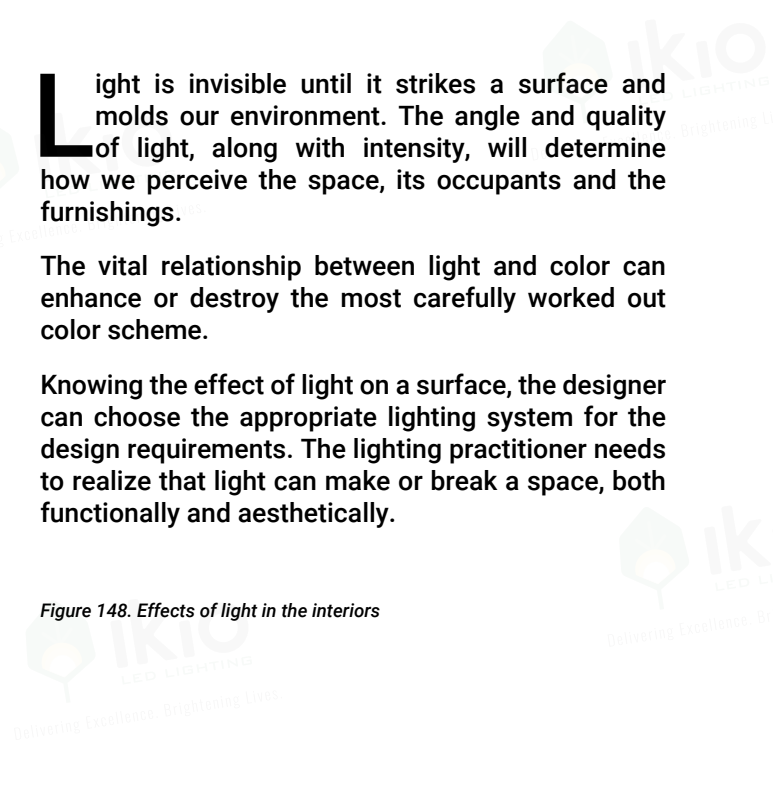

4 » Art and Science of Lighting

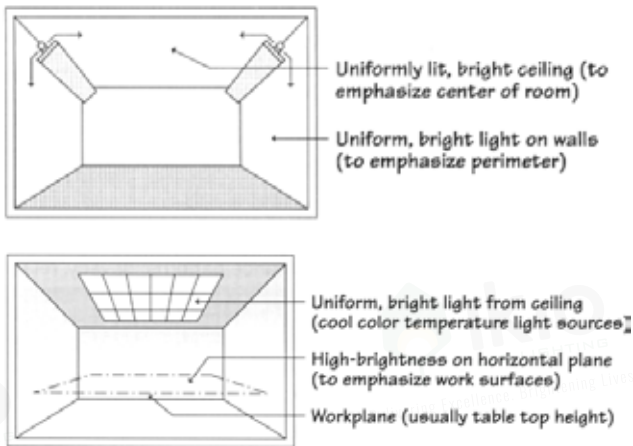

Where brightness occurs in a space establishes the character or feeling of that space:

- A ceiling left in shadow creates a secure, intimate, relaxing environment suitable for lounges, leisurely dining and boardrooms.
- High brightness on the ceiling creates a bright and cheerful or efficient and work-like atmosphere that is ideal for offices, classrooms and kitchens.
- High brightness on the vertical planes of a space draws attention to the walls, expanding the space visually. This technique is ideal for galleries, merchandising areas, lobbies and corridors.
- A pattern of varying levels of brightness can indicate direction and lead people through a space.

5 » Gitter & Sparkle

Pinpoints of brightness from small filaments or multiple reflections from crystal, chrome or other shiny surfaces create a scintillating effect that heightens awareness and gives an air of festivity to a space.

But whether used for dining, dancing or merchandising, glitter can become glare without sufficient background lighting to soften the contrast.

There is a fine line between stimulating points of brightness and discomfort glare.

6 » Light & Shadow



Figure 149. Scallops of light on a wall from nearby downlights and the shadows produced from an uplight under a plant or a small sculpture can create areas of visual interest that give character and individuality to a space.

An evenly illuminated space is similar to an overcast day; dull, monotonous, and boring. Variations in brightness and the interplay of light and shadow add variety to a space and provide visual relief and a sense of excitement.

Highlights provided by accent lighting create focal points that can direct attention or communicate an idea. When these lighting schemes work in concert, they provide excitement to the space and the objects within.

7 » Modelling



Shadows are essential for perceiving dimensionality. Three-dimensional objects lighted from directly in front appear flat, but when lighted from several directions, provide character.

Freestanding object, such as a sculpture, lighted from several directions with different intensities of color tints will appear three-dimensional.

Figure 150. An effective sculpture lighting design involves the use of lighting from several directions to highlight the three dimensional nature of the structure

8 » Lighting Design Considerations

The most important factor in a space is the people who will occupy it, use it, and live in it. People are not automatons; therefore, the psychological effects of an environment are as important as the physiological. Not only should good quality light be provided to “see by” but also to “feel by”.

The factors that should be considered in lighting any space are:

- **Function** - what will people do in the space?
- **Quantity and Quality of Light**- what’s needed to perform the tasks?
- **Architecture and Decor** - consider the aesthetic of the space
- **Atmosphere** - what is the mood or ambience of the space?
- **Situation** - is it a working, viewing, circulation or a living space?

9 » Creating the Total Environment

General and Ambient Lighting. This is light within a space that reduces harsh contrasts between pools of localized task or accent lighting. It is light that supplies a substantially even level of illumination throughout an area.

Accent Lighting. It is the role of accent lighting to emphasize a particular object or objects. It helps to provide the drama by creating visual interest on those items, which enhance the interior décor.

Task Lighting. Task lighting is supplementary illumination from nearby sources. It is designed to work in concert with the ambient lighting to provide the correct quantity and quality of illumination for visual performance.

Working together the ambient, task, and accent lighting present the total environment; both the architecture and the interior design.

10 » The Designer and the Engineer

A lighting designer assumes responsibility for determining how things will look and feel in a space. For a given space, the lighting designer must be able to understand and interpret the clients intent, devise a suitable lighting concept and translate it into a plan. Conceptual ideas are developed from continuous observation and analysis; hence the main contribution of the lighting designer to the

design process is creative vision.

An illuminating engineer on the other hand usually works from someone else's conceptual plan and provides the “how to” or solves the problems....optical, visual or mechanical....of making the concept work. Both are necessary for a successful design.



LIGHTING ESSENTIALS

LEARN ALL ABOUT
LIGHTING

PUBLISHED BY
IKIO LED LIGHTING

📍 8470 Allison Pointe Blvd, Suite 128 Indianapolis, IN 46250

☎ (T) 844-533-4546 (Toll Free)

✉ info@ikioledlighting.com

in www.linkedin.com/company/ikio-led-lighting

www.ikioledlighting.com